



**ELEMENTOS
INDUSTRIALES**

FERRETERIA INDUSTRIAL Y TRANSMISIONES

GUMMI

Embrague circunferencial Línea **FKT**



www.elementosindustriales.com.ar

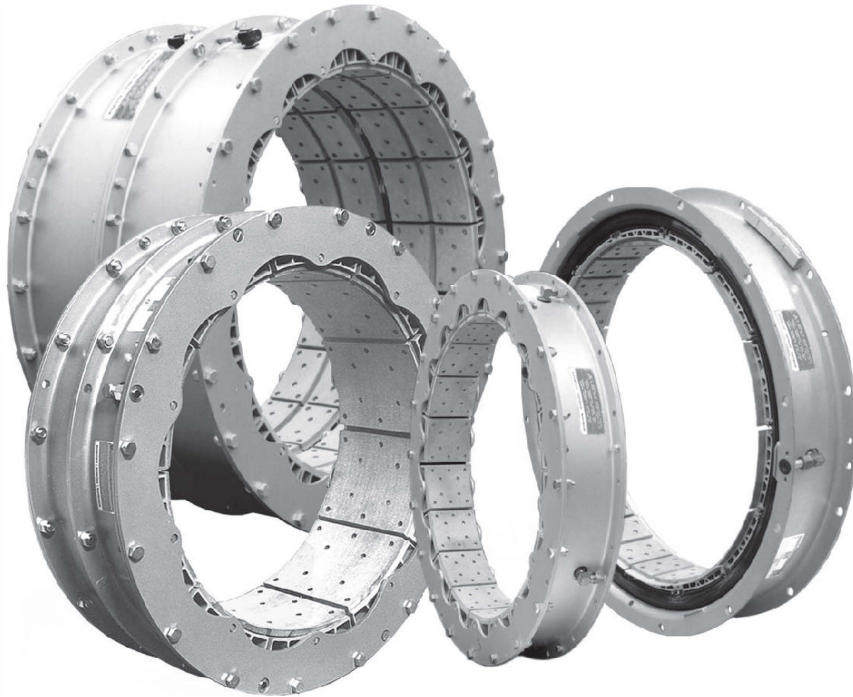

Contenidos

Características generales

Descripción de la llanta

Llanta FKT

Construcción y características

Componentes de la llanta FKT

Datos técnicos y dimensionales

Aplicación de embragues y frenos

Tipos de montaje

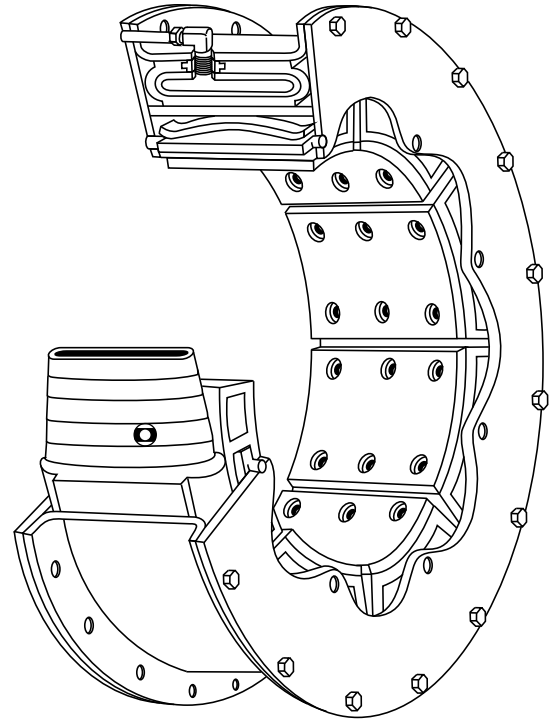

El tipo de llanta FKT está especialmente diseñada y construida para soportar severas acciones de embrague o freno, con grandes cargas de inercia y un sostenido patinamiento, que normalmente resultaría en una pérdida de torque y reduciría su vida útil.

El diseño y construcción de la llanta FKT es diferente a la FK y FM, dado que el torque es transmitido por una barra o perno de torque y no por la parte lateral de la cámara. En este caso la cámara está suelta en un alojamiento formado por un aro metálico y dos platos laterales siendo reemplazable. Las barras o pernos de torque están sujetas en posición por los platos laterales, pasando a través de las cavidades que tiene el respaldo de las zapatas de fricción.

Presurizando la cámara de aire, ésta presiona las zapatas sobre la superficie cilíndrica de la campana.

Una vez despresurizada la cámara, los flejes que actúan sobre las barras de torque, hacen que éstas se retracten arrastrando las zapatas de fricción, liberándolas.

La capacidad de transmitir torque de las llantas neumáticas depende de la presión de aire aplicada y el régimen de revoluciones. Los valores indicados en el catálogo corresponden a una presión de 7,5 psi (5,2 bar) y cero r.p.m. La presión máxima recomendada es de 12,5 psi (8,6 bar). Los valores de corrección de la presión figuran en la sección procedimiento de selección.

Las llantas FKT están disponibles en 22 tamaños y son identificadas por el \varnothing en pulgadas de la campana y el ancho en pulgadas de sus elementos de fricción. Para un mismo \varnothing de campana, es posible disponer de dos anchos diferentes de zapatas de fricción. Por esta razón las llantas se agrupan en dos series, angosta y ancha. Por ejemplo, la serie angosta sería 20-FKT-600, y la serie ancha 20-FKT-1000, trabajando las dos sobre una campana de \varnothing 20", la de serie angosta tiene 6" de ancho mientras que la de serie ancha tiene 10", la llanta más pequeña de la serie FKT trabaja sobre una campana de 11,5" (292 mm) de \varnothing , y la más grande sobre una de 66" (1.676 mm).

Dos llantas unidas forman una dual, esto hace que su capacidad de transmitir torque se duplique; esta disposición es factible con la serie angosta y la ancha indistintamente. El diseño FKT ofrece los siguientes aspectos adicionales a los descriptos en este último párrafo.

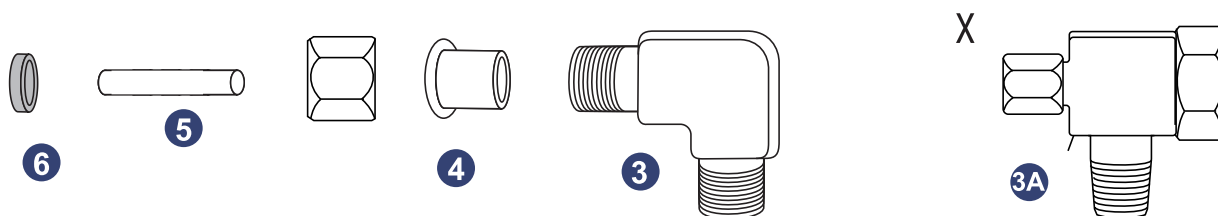
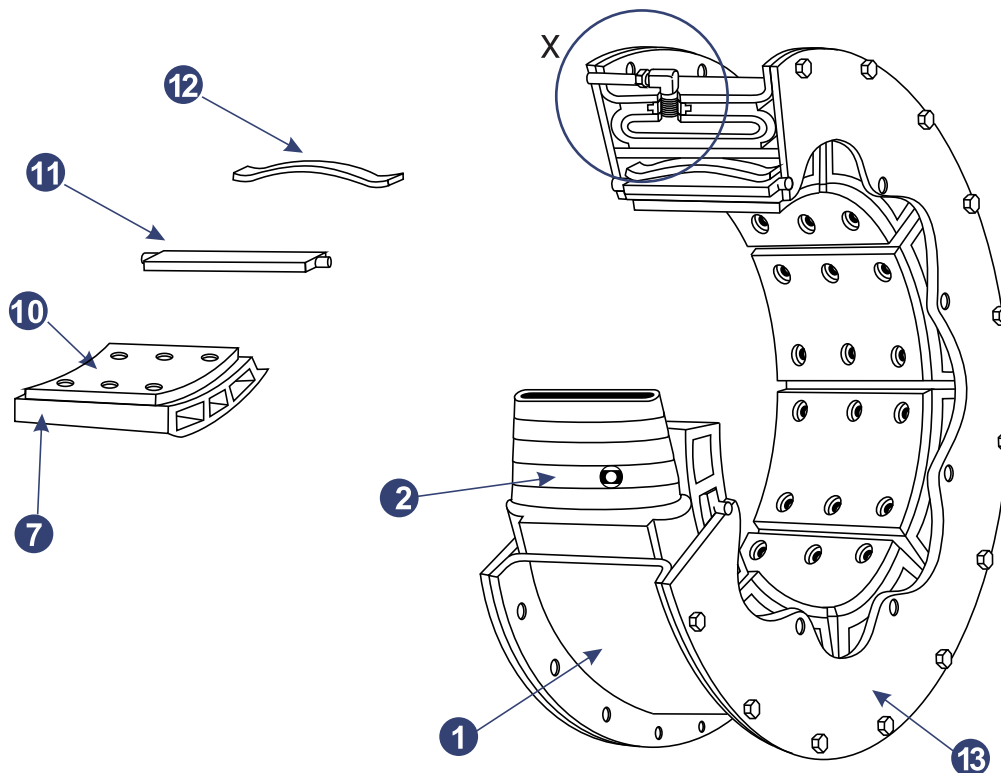

Tipo - FKT / RNT

- 1 - Cuerpo
- 2 - Cámara
- 3 - Codo
- 3A - Opcional válvula de escape rápido
- 4 - Anillo de compresión
- 5 - Tubo de conexión
- 6 - Junta selladora
- 7 - Zapata ventilada
- 8 - Tubo de conexión (montaje dual)
- 9 - Separadores (montaje dual)
- 10 - kit reemplazo ferodo y sujetador
- 11 - Barra de torque
- 12 - Fleje
- 13 - Plato lateral 2 piezas
- 7, 11, 12 - Kit zapata, barra de torque y fleje

NOTAS:

La opción de válvula de escape rápido no es aplicable al 11,5-FKT-500.

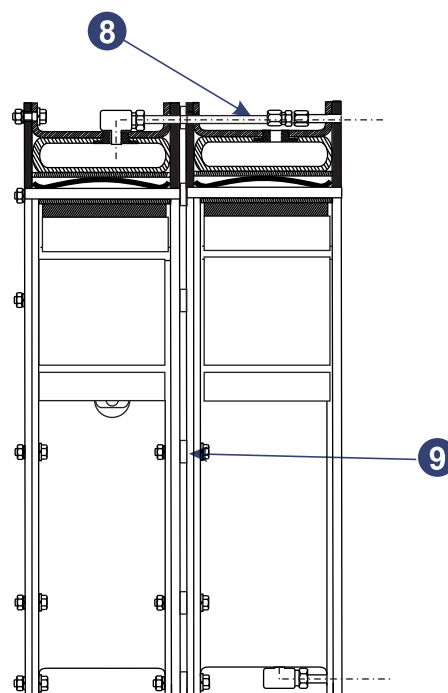

Datos técnicos

Tamaño 11,5 al 42

INGLES		lb.pulg @ 75 psi	rpm	psi/rpm ²	lb-ft ²	lb	pulg ²	Pulgadas		pulg ³	Pulgadas
								nuevo	usado		
11.5FKT500	101002	27000	1800	23	43	96	166	0.32	0.16	70	11.41
14FKT500	101050	39200	1500	28	78	128	205	0.32	0.16	95	13.91
16FKT600	101102	65000	1400	29	115	151	283	0.32	0.16	120	15.91
20FKT600	101152	93000	1200	40	193	179	380	0.32	0.16	140	19.88
24FKT650	101202	135000	1050	49	369	246	466	0.44	0.16	200	23.88
28FKT650	101252	182000	1000	58	537	280	548	0.44	0.16	270	27.81
33FKT650	101300	255000	900	74	1083	392	643	0.57	0.28	360	32.81
37FKT650	101350	320000	800	90	1400	433	720	0.57	0.28	400	36.81
42FKT650	101400	380000	800	95	1990	485	822	0.57	0.28	440	41.81
TAMAÑO	N° de Parte ¹	M. Torque Nominal ²	Máxima Velocidad ⁶	Constante de pérdida centrífuga	Wk ² J	Peso	Area de Fricción	Espesor del Revestimiento de fricción		Volumen de aire ⁷	Mínimo de Campana
11.5FKT500	101002	3050	1800	1.59	1.81	43	1071	8	4	1.15	290
14FKT500	101050	4430	1500	1.93	3.28	58	1322	8	4	1.56	353
16FKT600	101102	7346	1400	2.00	4.83	68	1825	8	4	1.97	404
20FKT600	101152	10511	1200	2.76	8.12	81	2451	8	4	2.30	505
24FKT650	101202	15258	1050	3.38	15.53	111	3006	11	4	3.28	607
28FKT650	101252	20570	1000	4.00	22.60	127	3535	11	4	4.43	706
33FKT650	101300	28821	900	5.11	45.59	178	4148	14.5	7	5.90	833
37FKT650	101350	36168	800	6.21	58.94	196	4645	14.5	7	6.56	935
42FKT650	101400	42949	800	6.56	83.77	220	5303	14.5	7	7.22	1062
SI		N·m @ 5,2 bar	rpm	Bar/rpm ²	Kg-m ²	Kg	cm ²	Espesor del Revestimiento de fricción		dm ³	Milímetros
								nuevo	usado		
								Milímetros			

* Los datos presentados en los catálogos son indicativos y sujetos a modificación sin previo aviso.

NOTAS:

- 1- Solicitar por n° de parte. Con solicitud indicar n° de entradas de aire y tipo de conexión.
- 2- El torque indicado es dinámico, el torque estático es aproximadamente 25 % mayor. El torque en cada aplicación depende de la presión de aire y la velocidad.
- 3- Tolerancia por tamaño:
11,5 al 20 + 0,000/-0,005 pulg. (+0,00/-0,13 mm).
24 al 28 + 0,000/-0,008 pulg. (+0,00/-0,20 mm).
33 al 42 + 0,000/-0,010 pulg. (+0,00/-0,25 mm).
- 4- Tolerancia + 0,005/-0,000 pulg. (+ 0,13/-0,00 mm).
- 5- Rosca NPT. Tamaño 11,5 disponible en 1 y 2 entradas de aire.
Todos los demás tamaños disponibles son de 4 entradas de aire.
- 6- Las máximas r.p.m. dependen del modo de operación y varían de acuerdo a cada aplicación.
Consultar a fábrica por aplicación que exceda las velocidades indicadas.
- 7- Con campana instalada y zapatas.

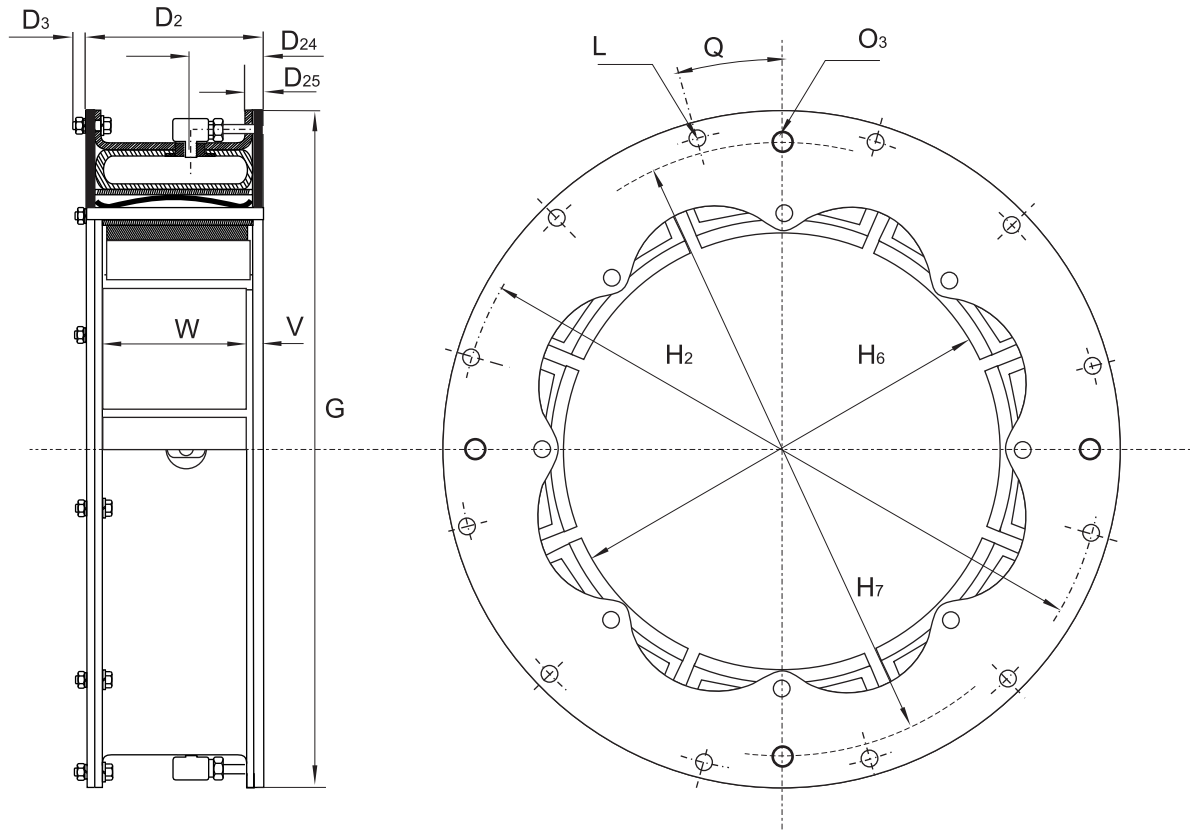

INGLES		lb.pulg @ 75 psi	Dimensiones en pulgadas																
11,5FKT500	101002	27000	6.13	0.23	2.38	0.38	19.625	18.875	11.63	18.88	16	0.375	0.31	2	3/8-18	11.25	0.56	8	5.00
14FKT500	101050	39200	6.13	0.31	2.88	0.58	23.500	22.500	14.22	22.25	8	0.500	0.38	4	3/8-18	22.50	0.56	8	5.00
16FKT600	101102	65000	7.38	0.31	2.88	0.59	25.500	24.375	16.22	24.38	12	0.500	0.38	4	3/8-18	15.00	0.69	8	6.00
20FKT600	101152	93000	7.38	0.31	2.88	0.59	29.500	28.375	20.22	28.38	12	0.500	0.38	4	3/8-18	15.00	0.69	10	6.00
24FKT650	101202	135000	7.69	0.39	2.88	0.63	34.000	32.750	24.22	32.50	16	0.625	0.50	4	1/2-14	11.25	0.59	12	6.50
28FKT650	101252	182000	7.69	0.39	2.88	0.63	38.000	36.750	28.22	36.50	16	0.625	0.50	4	1/2-14	11.25	0.59	14	6.50
33FKT650	101300	255000	7.69	0.47	3.13	0.63	44.625	43.125	33.22	43.25	18	0.750	0.63	4	3/4-14	15.00	0.59	16	6.50
37FKT650	101350	320000	7.69	0.47	3.13	0.69	48.625	47.125	37.22	47.25	20	0.750	0.63	4	3/4-14	9.00	0.59	18	6.50
42FKT650	101400	380000	7.69	0.47	3.13	0.69	53.625	52.125	42.22	52.25	24	0.750	0.63	4	3/4-14	7.50	0.59	20	6.50
Tamaño	N° de Parte	M. Torque Nomin. 2	D2	D3	D24	D25	G 3	H2	H6	H7	N° Día		O3	N° Tamaño		Q ángulo	V	N° ancho	
											L 4	N° Día		O4 5	N° Tamaño			W	N° ancho
11,5FKT500	101002	3050	156	6	60	10	498.5	479.4	295	479	16	9.5	8	2	3/8-18	11.25	14	8	127
14FKT500	101050	4430	156	8	73	15	596.9	571.5	361	565	8	12.7	10	4	3/8-18	22.50	14	8	127
16FKT600	101102	7346	187	8	73	15	647.7	619.1	412	619	12	12.7	10	4	3/8-18	15.00	17	8	152
20FKT600	101152	10511	187	8	73	15	749.3	720.7	514	721	12	12.7	10	4	3/8-18	15.00	17	10	152
24FKT650	101202	15258	195	10	73	16	863.6	831.9	615	826	16	15.9	13	4	1/2-14	11.25	15	12	165
28FKT650	101252	20570	195	10	73	16	965.2	933.5	717	927	16	15.9	13	4	1/2-14	11.25	15	14	165
33FKT650	101300	28821	195	12	79	16	1133.5	1095.4	844	1099	18	19.1	16	4	3/4-14	15.00	15	16	165
37FKT650	101350	36168	195	12	79	17	1235.1	1197.0	945	1200	20	19.1	16	4	3/4-14	9.00	15	18	165
42FKT650	101400	42949	195	12	79	17	1362.1	1324.0	1072	1327	24	19.1	16	4	3/4-14	7.50	15	20	165
SI	N-m @ 5.2 bar		Dimensiones en milímetros																

* Los datos presentados en los catálogos son indicativos y sujetos a modificación sin previo aviso.



FKT Dual - Serie Angosta

Datos técnicos

Tamaño 11,5 al 42

INGLES		lb.pulg @ 75 psi	rpm	psi/rpm ²	lb-ft ²	lb	pulg ²	Pulgadas		pulg ³	Pulgadas
								nuevo	usado		
11.5FKT500	101006	54000	1800	23	86	197	332	0.32	0.16	140	11.41
14FKT500	101060	78400	1500	28	156	258	410	0.32	0.16	190	13.91
16FKT600	101109	130000	1400	29	230	307	566	0.32	0.16	240	15.91
20FKT600	101158	186000	1200	40	386	363	760	0.32	0.16	280	19.88
24FKT650	101208	270000	1050	49	738	497	932	0.44	0.16	400	23.88
28FKT650	101260	364000	1000	58	1074	565	1096	0.44	0.16	540	27.81
33FKT650	101303	510000	900	74	2166	784	1286	0.57	0.28	720	32.81
37FKT650	101358	640000	800	90	2800	871	4110	0.57	0.28	800	36.81
42FKT650	101402	760000	800	95	3980	980	1644	0.57	0.28	880	41.81
TAMAÑO	N° de Parte ①	M. Torque Nominal ②	Máxima Velocidad ⑥	Constante de pérdida centrifuga	Wk ² J	Peso Peso	Area de Fricción	Espesor del Revestimiento de fricción		Volumen de aire	Mínimo de Campana
11.5FKT500	101006	6100	1800	1.59	3.62	89	2141	8	4	2.30	290
14FKT500	101060	8860	1500	1.93	6.57	117	2645	8	4	3.12	353
16FKT600	101109	14690	1400	2.00	9.68	139	3651	8	4	3.94	404
20FKT600	101158	21020	1200	2.76	16.25	164	4903	8	4	4.59	505
24FKT650	101208	30516	1050	3.38	31.07	225	6013	11	4	6.56	607
28FKT650	101260	41141	1000	4.00	45.22	256	7071	11	4	8.86	706
33FKT650	101303	57642	900	5.11	91.19	355	8296	14.5	7	11.8	833
37FKT650	101358	72336	800	6.21	117.8	395	9290	14.5	7	13.1	935
42FKT650	101402	85900	800	6.56	167.5	444	10606	14.5	7	14.4	1062
SI		N·m @ 5,2 bar	rpm	Bar/rpm ²	Kg·m ²	Kg	cm ²	Milímetros		dm ³	Milímetros
								nuevo	usado		

* Los datos presentados en los catálogos son indicativos y sujetos a modificación sin previo aviso.

NOTAS:

- 1- Solicitar por n° de parte. Con solicitud indicar n° de entradas de aire y tipo de conexión.
- 2- El torque indicado es dinámico, el torque estático es aproximadamente 25 % mayor. El torque en cada aplicación depende de la presión de aire y la velocidad.
- 3- Tolerancia por tamaño:
 11,5 al 20 + 0,000/-0,005 pulg. (+0,00/-0,13 mm).
 24 al 28 + 0,000/-0,008 pulg. (+0,00/-0,20 mm).
 33 al 42 + 0,000/-0,010 pulg. (+0,00/-0,25 mm).
- 4- Tolerancia + 0,005/-0,000 pulg. (+ 0,13/-0,00 mm).
- 5- Rosca NPT. Tamaño 11,5 disponible en 1 y 2 entradas de aire.
 Todos los demás tamaños disponibles con 2 ó 4 entradas de aire.
- 6- Las máximas r.p.m. dependen del modo de operación y varían de acuerdo a cada aplicación.
 Consultar a fábrica por aplicación que exceda las velocidades indicadas.

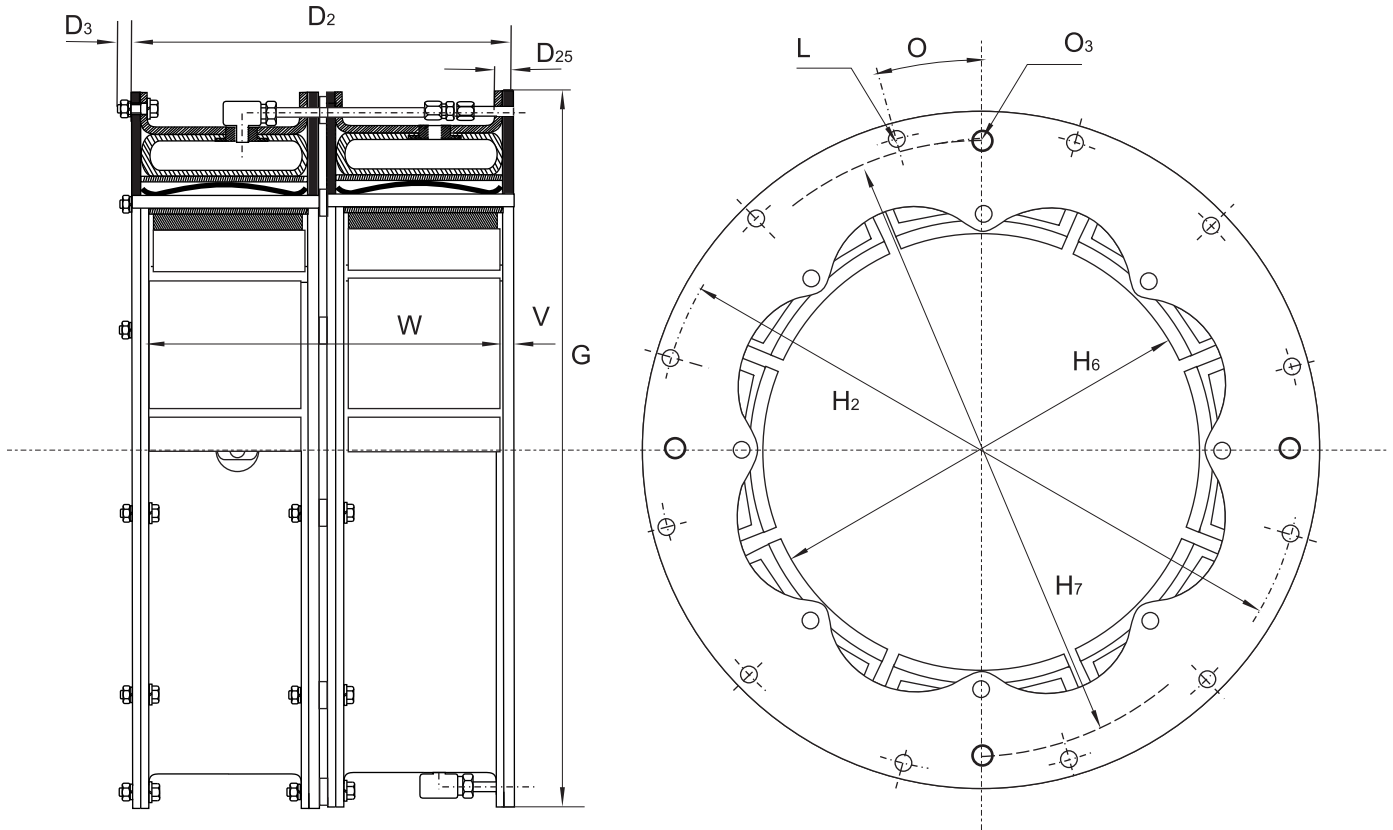

INGLES		lb.pulg @ 75 psi	Dimensiones en pulgadas														
11,5FKT500	101006	54000	12.75	0.23	0.56	19.625	18.875	11.63	18.88	16	0.375	2	0.31	11.25	0.56	16	11.63
14FKT500	101060	78400	12.69	0.31	0.56	23.500	22.500	14.22	22.25	8	0.500	4	0.38	22.50	0.56	16	11.57
16FKT600	101109	130000	15.19	0.31	0.56	25.500	24.375	16.22	24.38	12	0.500	4	0.38	15.00	0.69	16	13.81
20FKT600	101158	186000	15.19	0.31	0.56	29.500	28.375	20.22	28.38	12	0.500	4	0.38	15.00	0.69	20	13.81
24FKT650	101208	270000	15.94	0.39	0.63	34.000	32.750	24.22	32.50	16	0.625	4	0.50	11.25	0.59	24	14.75
28FKT650	101260	364000	15.94	0.39	0.63	38.000	36.750	28.22	36.50	16	0.625	4	0.50	11.25	0.59	28	14.75
33FKT650	101303	510000	15.94	0.47	0.69	44.625	43.125	33.22	43.25	18	0.750	4	0.63	15.00	0.59	32	14.75
37FKT650	101358	64000	15.94	0.47	0.69	48.625	47.125	37.22	47.25	20	0.750	4	0.63	9.00	0.59	36	14.75
42FKT650	101402	760000	15.94	0.47	0.69	53.625	52.125	42.22	52.25	24	0.750	4	0.63	7.50	0.59	40	14.75
Tamaño	N° de Parte ¹	M. Torque Nomin. ²	D2	D3	D24	G ³	H2	H6	H7	N° Día		N° Tamaño		Q ángulo	V	N° ancho	
										L ⁴	O3 ⁵	W					
11,5FKT500	101006	6100	324	6	14	498.5	479.4	295	479	16	9.5	2	8	11.25	14	16	295
14FKT500	101060	8860	322	8	14	596.9	571.5	361	565	8	12.7	4	10	22.50	14	16	294
16FKT600	101109	14690	386	8	14	647.7	619.1	412	619	12	12.7	4	10	15.00	17	16	351
20FKT600	101158	21020	386	8	14	749.3	720.7	514	721	12	12.7	4	10	15.00	17	20	351
24FKT650	101208	30516	405	10	16	863.6	831.9	615	826	16	15.9	4	13	11.25	15	24	375
28FKT650	101260	41141	405	10	16	965.2	933.5	717	927	16	15.9	4	13	11.25	15	28	375
33FKT650	101303	57642	405	12	18	1133.5	1095.4	844	1099	18	19.1	4	16	15.00	15	32	375
37FKT650	101358	72336	405	12	18	1235.1	1197.0	945	1200	20	19.1	4	16	9.00	15	36	375
42FKT650	101402	85900	405	12	18	1362.1	1324.0	1072	1327	24	19.1	4	16	7.50	15	40	375
SI	N-m @ 5.2 bar		Dimensiones en milímetros														

* Los datos presentados en los catálogos son indicativos y sujetos a modificación sin previo aviso.



FKT Simple - Serie Ancha



Datos Técnicos

Tamaño 14 al 66

INGLES		lb.pulg @ 75 psi	rpm	psi/rpm ²	lb-ft ²	lb	pulg ²	Pulgadas		pulg ³	Pulgadas
								nuevo	usado		
14FKT1000	102030	85000	1800	22	127	213	350	0.32	0.16	185	13.91
16FKT1000	102000	114000	1400	27	212	240	470	0.32	0.16	255	15.91
20FKT1000	102050	161000	1300	37	309	282	635	0.32	0.16	310	19.87
24FKT1000	102100	219000	1250	46	552	378	720	0.44	0.16	465	23.87
28FKT1000	102150	296000	1100	55	826	431	840	0.44	0.16	530	27.81
32FKT1000	102200	415000	1050	63	1570	624	960	0.57	0.38	600	31.81
38FKT1200	102250	680000	740	82	2330	684	1360	0.57	0.38	755	37.81
42FKT1200	102300	819000	670	86	3670	895	1500	0.57	0.38	850	41.75
46FKT1200	102350	950000	600	108	4830	980	1410	0.68	0.38	1205	45.75
52FKT1200	102400	1215000	550	127	7285	1192	1590	0.68	0.38	1510	51.75
51FKT1600	102450	1610000	550	125	10580	1934	2380	0.66	0.30	2000	50.75
60FKT1600	102500	2183000	520	145	20532	2450	2800	0.66	0.30	2350	59.75
66FKT1600	102550	2800000	480	186	24850	2630	3080	0.66	0.30	1960	65.75

TAMAÑO	N° de Parte ¹	M. Torque Nominal ²	Máxima Velocidad ⁶	Constante de pérdida centrífuga	Wk ² J	Peso Peso	Area de Fricción	Espesor del Revestimiento de fricción		Volumen de aire ⁷	Mínimo de Campana
14FKT1000	102030	9607	1800	1.52	5.33	96	2258	8	4	3.03	353
16FKT1000	102000	12884	1400	1.86	8.93	109	3032	8	4	4.18	404
20FKT1000	102050	18197	1300	2.55	13.01	128	4096	8	4	5.08	505
24FKT1000	102100	24752	1250	3.17	23.24	171	4645	11	4	7.63	606
28FKT1000	102150	33455	1100	3.80	34.77	195	5419	11	4	8.69	706
32FKT1000	102200	46905	1050	4.35	66.10	283	6193	14	10	9.84	808
38FKT1200	102250	76857	740	5.66	98.09	310	8774	14	10	12.4	960
42FKT1200	102300	92567	670	5.93	154.5	406	9677	14	10	13.9	1060
46FKT1200	102350	107373	600	7.45	203.3	444	10580	17	10	19.8	1162
52FKT1200	102400	137325	550	8.76	306.7	540	10258	17	10	24.8	1314
51FKT1600	102450	181970	550	8.63	445.4	877	15354	17	8	32.8	1289
60FKT1600	102500	246733	520	10.01	864.4	1111	18064	17	8	38.5	1518
66FKT1600	102550	316470	480	12.83	1046.1	1193	19870	17	8	32.1	1670

SI	N·m @ 5,2 bar	rpm	Bar/rpm ²	Kg·m ²	Kg	cm ²	nuevo usado Milímetros		dm ³	Milímetros
----	---------------	-----	----------------------	-------------------	----	-----------------	---------------------------	--	-----------------	------------

* Los datos presentados en los catálogos son indicativos y sujetos a modificación sin previo aviso.

NOTAS:

- 1- Solicitar por n° de parte. Con solicitud indicar n° de entradas de aire y tipo de conexión.
- 2- El torque indicado es dinámico, el torque estático es aproximadamente 25 % mayor. El torque en cada aplicación depende de la presión de aire y la velocidad.
- 3- Tolerancia por tamaño:
 14 al 20 + 0,000/-0,005 pulg. (+0,00/-0,13 mm).
 24 al 28 + 0,000/-0,008 pulg. (+0,00/-0,20 mm).
 32 al 60 + 0,000/-0,010 pulg. (+0,00/-0,25 mm).
 66 + 0,000/-0,005 pulg. (+0,00/-0,13 mm).
- 4- Tolerancia + 0,005/-0,000 pulg. (+ 0,13/-0,00 mm).
- 5- Rosca NPT.
- 6- Las máximas r.p.m. dependen del modo de operación y varían de acuerdo a cada aplicación. Consultar a fábrica por aplicación que exceda las velocidades indicadas.
- 7- Con campana instalada y zapatas.



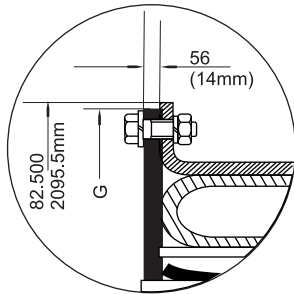

Construcción para tamaño 66" solamente

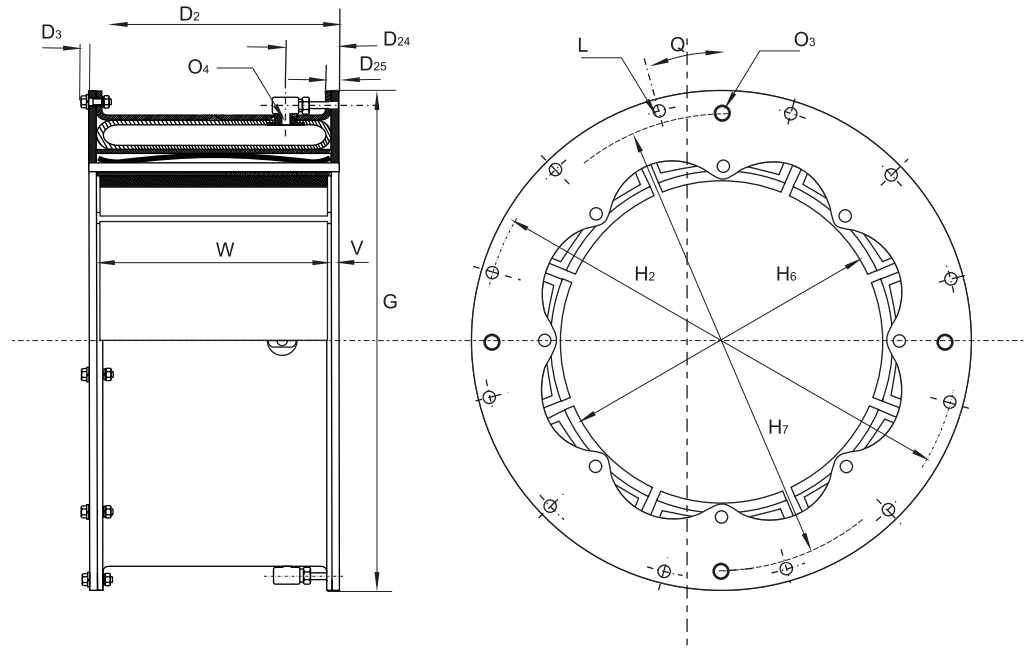

INGLES		lb.pulg @ 75 psi	Dimensiones en pulgadas																
14FKT1000	102030	85000	11.56	0.31	2.88	0.63	23.500	22.500	14.22	22.25	8	0.500	0.38	4	3/8-18	22.50	0.78	8	10
16FKT1000	102000	114000	11.56	0.31	2.88	0.63	25.500	24.375	16.22	24.38	12	0.500	0.38	4	3/8-18	15.00	0.78	8	10
20FKT1000	102050	161000	11.56	0.31	2.88	0.63	29.500	28.375	20.22	28.38	12	0.500	0.38	4	3/8-18	15.00	0.78	8	10
24FKT1000	102100	219000	11.56	0.39	2.88	0.63	34.000	32.750	24.22	32.50	16	0.625	0.50	4	1/2-14	11.25	0.78	10	10
28FKT1000	102150	296000	11.56	0.39	2.88	0.63	38.000	36.750	28.22	36.50	16	0.625	0.50	4	1/2-14	11.25	0.78	10	10
32FKT1000	102200	415000	11.63	0.39	2.88	0.63	44.875	42.625	32.22	42.13	24	.0625	0.50	4	1/2-14	7.50	0.81	12	10
38FKT1200	102250	680000	13.75	0.47	3.13	0.69	49.375	47.875	38.22	48.00	20	0.750	0.63	4	3/4-14	9.00	0.88	12	12
42FKT1200	102300	819000	13.75	0.47	3.13	0.66	53.625	52.125	42.22	52.25	24	0.750	0.63	4	3/4-14	7.50	0.88	14	12
46FKT1200	102350	950000	13.75	0.55	4.88	0.78	60.250	58.500	46.25	57.50	24	0.875	0.63	4	3/4-14	7.50	0.88	16	12
52FKT1200	102400	1215000	14.25	0.55	7.13	1.03	67.000	65.500	52.25	65.00	32	.0875	0.88	4	1-11 1/2	5.63	1.13	18	12
51FKT1600	102450	1610000	18.25	0.55	9.13	1.13	67.000	65.500	51.25	65.00	32	0.875	0.88	4	1-11 1/2	5.63	1.13	18	16
60FKT1600	102500	2183000	18.50	0.61	9.25	1.38	77.000	75.000	60.43	74.25	36	1.000	0.88	4	1-11 1/2	5.00	1.25	20	16
66FKT1600	102550	2800000	18.50	0.78	9.25	1.38	82.123	79.625	60.22	78.38	40	1.312	0.88	4	1-11 1/2	5.00	1.25	22	16
Tamaño	Nº de Parte	M. Torque Nomin.	D2	D3	D24	D25	G	H2	H6	H7	Nº Día	L	O3	Nº Tamaño	Q ángulo	V	Nº ancho	W	Nº ancho
14FKT1000	102030	8607	294	8	73	16	596.9	571.5	361	565	8	12.7	10	4	3/8-18	22.50	20	8	254
16FKT1000	102000	12884	294	8	73	16	647.7	619.1	412	619	12	12.7	10	4	3/8-18	15.00	20	8	254
20FKT1000	102050	18197	294	8	73	16	749.3	720.7	514	721	12	12.7	10	4	3/8-18	15.00	20	8	254
24FKT1000	102100	24752	294	10	73	16	863.6	831.9	615	826	16	15.9	13	4	1/2-14	11.25	20	10	254
28FKT1000	102150	33455	294	10	73	16	965.2	933.5	717	927	16	15.9	13	4	1/2-14	11.25	20	10	254
32FKT1000	102200	46905	295	10	73	16	1114.4	1082.7	818	1070	24	15.9	13	4	1/2-14	7.50	21	12	254
38FKT1200	102250	76857	349	12	79	18	1254.1	1216.0	971	1219	20	19.1	16	4	3/4-14	9.00	22	12	305
42FKT1200	102300	92567	349	12	79	17	1362.1	1324.0	1072	1327	24	19.1	16	4	3/4-14	7.50	22	14	305
46FKT1200	102350	107373	349	14	124	20	1530.4	1485.9	1175	1461	24	22.2	16	4	3/4-14	7.50	22	16	305
52FKT1200	102400	137325	362	14	181	26	1701.8	1663.7	1327	1651	32	22.2	22	4	1-11 1/2	5.63	29	18	305
51FKT1600	102450	181970	464	14	232	29	1701.8	1663.7	1302	1651	32	22.2	22	4	1-11 1/2	5.63	29	18	406
60FKT1600	102500	246733	470	15	235	35	1955.8	1905.0	1535	1886	36	25.4	22	4	1-11 1/2	5.00	32	20	406
66FKT1600	102550	316470	470	20	235	35	2085.9	2022.5	1535	1991	40	33.3	22	4	1-11 1/2	5.00	32	22	406
SI	N-m @ 5.2 bar	Dimensiones en milímetros																	

* Los datos presentados en los catálogos son indicativos y sujetos a modificación sin previo aviso.



Datos Técnicos

Tamaño 16 al 66

INGLES	lb.pulg @ 75 psi	rpm	psi/rpm ²	lb-ft ²	lb	pulg ²	Pulgadas		pulg ³	Pulgadas	
							nuevo	usado			
16FKT1000	102008	228000	1400	27	380	430	940	0.32	0.16	510	15.91
20FKT1000	102058	322000	1300	37	618	568	1270	0.32	0.16	620	19.87
24FKT1000	102101	438000	1250	46	1104	756	1440	0.44	0.16	930	23.87
28FKT1000	102158	592000	1100	55	1652	862	1680	0.44	0.16	1060	27.81
32FKT1000	102208	830000	1050	63	3140	1248	1920	0.57	0.38	1200	31.81
38FKT1200	102258	1360000	740	82	4660	1368	2720	0.57	0.38	1510	37.81
42FKT1200	102308	1638000	670	86	7340	1790	3000	0.57	0.38	1700	41.75
46FKT1200	102358	1900000	600	108	9660	1960	3280	0.68	0.38	2410	45.75
52FKT1200	102408	2430000	550	127	14570	2384	3180	0.68	0.38	3020	51.75
51FKT1600	102458	3220000	550	125	21160	3868	4760	0.66	0.30	4000	50.75
60FKT1600	102508	4366000	520	145	41064	4900	5600	0.66	0.30	4700	59.75
66FKT1600	102558	5600000	480	186	49700	5260	6160	0.66	0.30	3920	65.75

TAMAÑO	Nº de Parte ①	M. Torque Nominal ②	Máxima Velocidad ⑥	Constante de pérdida centrífuga	Wk ² J	Peso Peso	Area de Fricción	Espesor del Revestimiento de fricción		Volumen de aire ⑦	Mínimo de Campana
16FKT1000	102008	25800	1400	1.86	16.00	195	6064	8	4	8.36	404
20FKT1000	102058	36400	1300	2.55	26.02	257	8193	8	4	10.2	505
24FKT1000	102101	49500	1250	3.17	46.48	342	9290	11	4	15.3	606
28FKT1000	102158	66900	1100	3.80	69.55	391	10838	11	4	17.4	706
32FKT1000	102208	93800	1050	4.35	132.1	566	12387	14	10	19.7	808
38FKT1200	102258	154000	740	5.66	196.1	620	17548	14	10	24.8	960
42FKT1200	102308	185000	670	5.93	309.0	811	19354	14	10	27.9	1060
46FKT1200	102358	215000	600	7.45	406.6	889	21161	17	10	39.5	1162
52FKT1200	102408	275000	550	8.76	613.4	1081	20516	17	10	49.5	1314
51FKT1600	102458	364000	550	8.63	890.8	1754	30709	17	8	65.6	1289
60FKT1600	102508	493000	520	10.01	1728	2222	36128	17	8	77.1	1518
66FKT1600	102558	633000	480	12.83	2092	2385	39741	17	8	64.3	1670

SI	N·m @ 5,2 bar	rpm	Bar/rpm ²	Kg·m ²	Kg	cm ²	Milímetros		dm ³	Milímetros
							nuevo	usado		

* Los datos presentados en los catálogos son indicativos y sujetos a modificación sin previo aviso.

NOTAS:

- 1- Solicitar por nº de parte. Con solicitud indicar nº de entradas de aire y tipo de conexión.
- 2- El torque indicado es dinámico, el torque estático es aproximadamente 25 % mayor. El torque en cada aplicación depende de la presión de aire y la velocidad.
- 3- Tolerancia por tamaño:
 16 al 20 + 0,000/-0,005 pulg. (+0,00/-0,13 mm).
 24 al 28 + 0,000/-0,008 pulg. (+0,00/-0,20 mm).
 32 al 60 + 0,000/-0,010 pulg. (+0,00/-0,25 mm).
 66 + 0,000/-0,005 pulg. (+0,00/-0,13 mm).
- 4- Tolerancia + 0,005/-0,000 pulg. (+ 0,13/-0,000 mm).
- 5- Todos los tamaños disponibles en 2 ó 4 entradas indistintamente.
- 6- Las máximas r.p.m. dependen del modo de operación y varían de acuerdo a cada aplicación. Consultar a fábrica por aplicación que excedan las velocidades indicadas.
- 7- Con campana instalada y zapatas.

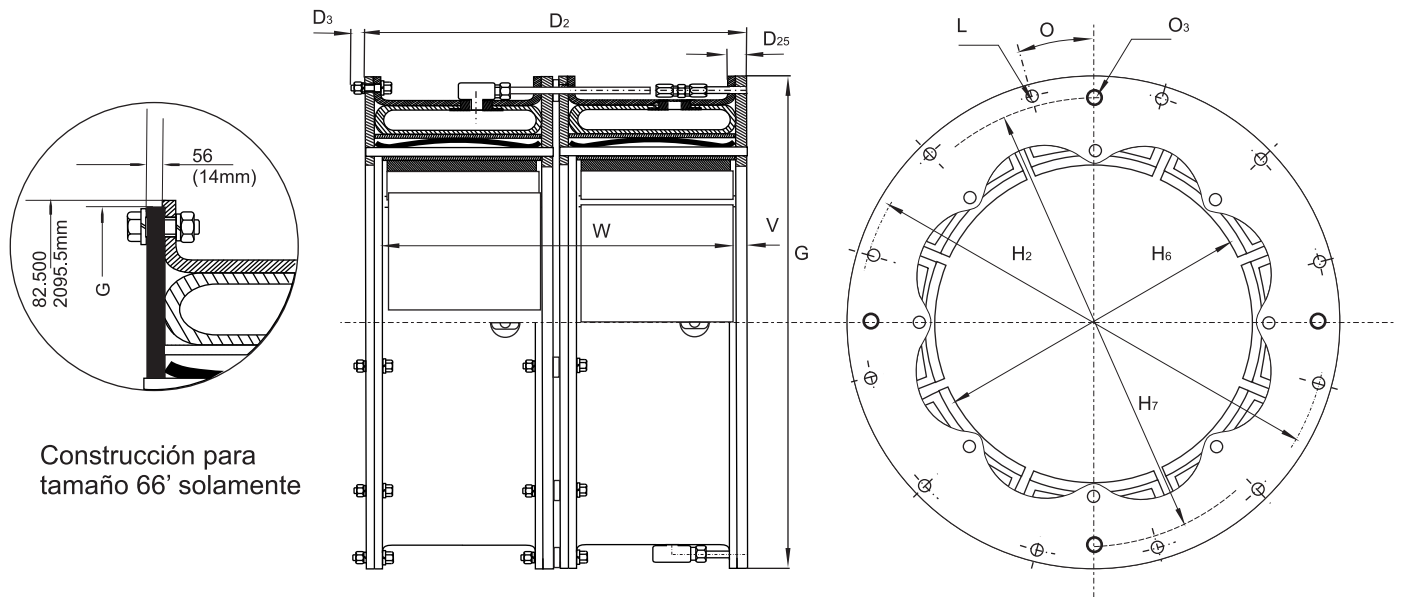

INGLES		lb.pulg @ 75 psi	Dimensiones en pulgadas														
16FKT1000	102008	228000	23.69	0.31	0.63	25.500	24.375	16.22	24.38	12	0.500	4	0.38	15.00	0.78	16	22.13
20FKT1000	102058	322000	23.69	0.31	0.63	29.500	28.375	20.22	28.38	12	0.500	4	0.38	15.00	0.78	16	22.13
24FKT1000	102101	438000	23.69	0.39	0.63	34.000	32.750	24.22	32.50	16	0.625	4	0.50	11.25	0.78	20	22.13
28FKT1000	102158	592000	23.69	0.39	0.63	38.000	36.750	28.22	36.50	16	0.625	4	0.50	11.25	0.78	20	22.13
32FKT1000	102208	830000	23.81	0.39	0.63	43.875	42.625	32.22	42.13	24	.0625	4	0.50	7.50	0.81	24	23.19
38FKT1200	102258	1360000	28.06	0.47	0.66	49.375	47.875	38.22	48.00	20	0.750	4	0.63	9.00	0.88	24	26.31
42FKT1200	102308	1638000	28.06	0.47	0.66	53.625	52.125	42.22	52.25	24	0.750	4	0.63	7.50	0.88	28	26.31
46FKT1200	102358	1900000	28.06	0.55	0.75	60.250	58.500	46.25	57.50	24	0.875	4	0.63	7.50	0.88	32	26.31
52FKT1200	102408	2430000	29.06	0.55	1.13	67.000	65.500	52.25	65.00	32	.0875	4	0.88	5.63	1.13	36	26.81
51FKT1600	102458	3220000	37.06	0.55	1.13	67.000	65.500	51.25	65.00	32	0.875	4	0.88	5.63	1.13	36	34.81
60FKT1600	102508	4366000	37.56	0.61	1.38	77.000	75.000	60.43	74.25	36	1.000	4	0.88	5.00	1.25	40	35.06
66FKT1600	102558	5600000	37.00	0.78	1.38	82.123	79.625	66.22	78.38	40	1.312	4	0.88	4.50	1.25	44	34.50
Tamaño	Nº de Parte ①	M. Torque Nomin. ②	D2	D3	D25	G ③	H2	H6	H7	Nº Día		Nº Día		Q	V	Nº ancho	
										L ④	O3 ⑤	ángulo			W		
										Nº Día	Nº Día				Nº ancho		
16FKT1000	102008	25800	602	8	16	647.7	619.1	412	619	12	12.7	4	10	15.00	20	16	562
20FKT1000	102058	36400	602	8	16	749.3	720.7	514	721	12	12.7	4	10	15.00	20	16	562
24FKT1000	102101	49500	602	10	16	863.6	831.9	615	826	16	15.9	4	13	11.25	20	20	562
28FKT1000	102158	66900	602	10	16	965.2	933.5	717	927	16	15.9	4	13	11.25	20	20	562
32FKT1000	102208	93800	605	10	16	1114.4	1082.7	818	1070	24	15.9	4	13	7.50	21	24	589
38FKT1200	102258	154000	713	12	17	1254.1	1216.0	971	1219	20	19.1	4	16	9.00	22	24	668
42FKT1200	102308	185000	713	12	17	1362.1	1324.0	1072	1327	24	19.1	4	16	7.50	22	28	668
46FKT1200	102358	215000	713	14	19	1530.4	1485.9	1175	1461	24	22.2	4	16	7.50	22	32	668
52FKT1200	102408	275000	738	14	29	1701.8	1663.7	1327	1651	32	22.2	4	22	5.63	29	36	681
51FKT1600	102458	364000	941	14	29	1701.8	1663.7	1302	1651	32	22.2	4	22	5.63	29	36	884
60FKT1600	102508	493000	954	15	35	1955.8	1905.0	1535	1886	36	25.4	4	22	5.00	32	40	891
66FKT1600	102558	633000	940	20	35	2085.9	2022.5	1682	1991	40	33.3	4	22	4.50	32	44	876
SI		N-m @ 5.2 bar	Dimensiones en milímetros														

* Los datos presentados en los catálogos son indicativos y sujetos a modificación sin previo aviso.



INGLES	lb	lb-ft ²	lb	lb-ft ²	lb	lb-ft ²	lb	lb-ft ²	lb	lb-ft ²
11,5FKT500	96	43	28	13	54	4	46	9	35	2
14FKT500	128	78	38	26	82	8	66	19	65	4
16FKT600	151	115	48	40	99	14	94	35	62	4
20FKT600	179	193	56	63	147	34	139	78	95	9
24FKT650	246	369	74	110	192	56	178	148	124	19
28FKT650	280	537	81	157	250	106	231	269	240	59
33FKT650	392	1083	96	255	374	214	312	486	347	93
37FKT650	433	1400	121	381	434	294	340	691	398	159
42FKT650	485	1990	143	575	633	536	424	1100	545	243
TAMAÑO	Peso	Wk ²	Peso	Wk ²	Peso	Wk ²	Peso	Wk ²	Peso	Wk ²
	Llanta		Adaptador		Cubo Adaptador		Campana		Porta Campana	
	Peso	J	Peso	J	Peso	J	Peso	J	Peso	J
11,5FKT500	43	1.81	13	0.55	24	0.17	21	0.38	16	0.08
14FKT500	58	3.28	17	1.09	37	0.34	30	0.80	29	0.17
16FKT600	68	4.84	22	1.68	45	0.59	43	1.47	28	0.17
20FKT600	81	8.12	25	2.65	67	1.43	63	3.28	43	0.38
24FKT650	111	15.53	34	4.63	87	2.35	81	6.23	56	0.80
28FKT650	127	22.60	37	6.61	113	4.46	105	11.32	109	2.48
33FKT650	178	45.59	44	10.73	169	9.00	141	20.46	157	3.91
37FKT650	196	58.94	55	16.04	197	12.37	154	29.09	180	6.69
42FKT650	220	83.77	65	24.20	287	22.56	192	46.31	247	10.23
SI	Kg	Kg-m ²	Kg	Kg-m ²	Kg	Kg-m ²	Kg	Kg-m ²	Kg	Kg-m ²

TAMAÑO	N° de Parte				
	Llanta ⁷	Adaptador	Cubo Adaptador	Campana	Porta Campana
11,5FKT500	101002	216901	216630	216032	216330
14FKT500	101050	216902	216640	216042	216340
16FKT600	101102	216903	216650	216052	216350
20FKT600	101152	216904	216660	216062	216360
24FKT650	101202	216905	216670	216072	216370
28FKT650	101252	216906	216680	216082	216380
33FKT650	101300	216907	216790	216092	216390
37FKT650	101350	216908	216700	216102	216400
42FKT650	101400	216909	216710	216112	216410

* Los datos presentados en los catálogos son indicativos y sujetos a modificación sin previo aviso.

NOTAS:

- 1- Solicitar por n° de parte, no incluye unión giratoria ni manguera.
- 2- El torque indicado es dinámico, el torque estático es aproximadamente 25 % mayor. El torque en cada aplicación depende de la presión de aire y la velocidad.
- 3- Peso referido a mínimo Ø de eje. No incluye unión giratoria ni manguera.
- 4- Rosca NPT.
- 5- Referente a unión giratoria, ver información de montaje y dimensiones.
- 6- Peso referido a mínimo Ø de eje.
- 7- Referido al n° de parte básico únicamente.
Con la solicitud indicar el n° de entradas de aire y el tipo de conexión.

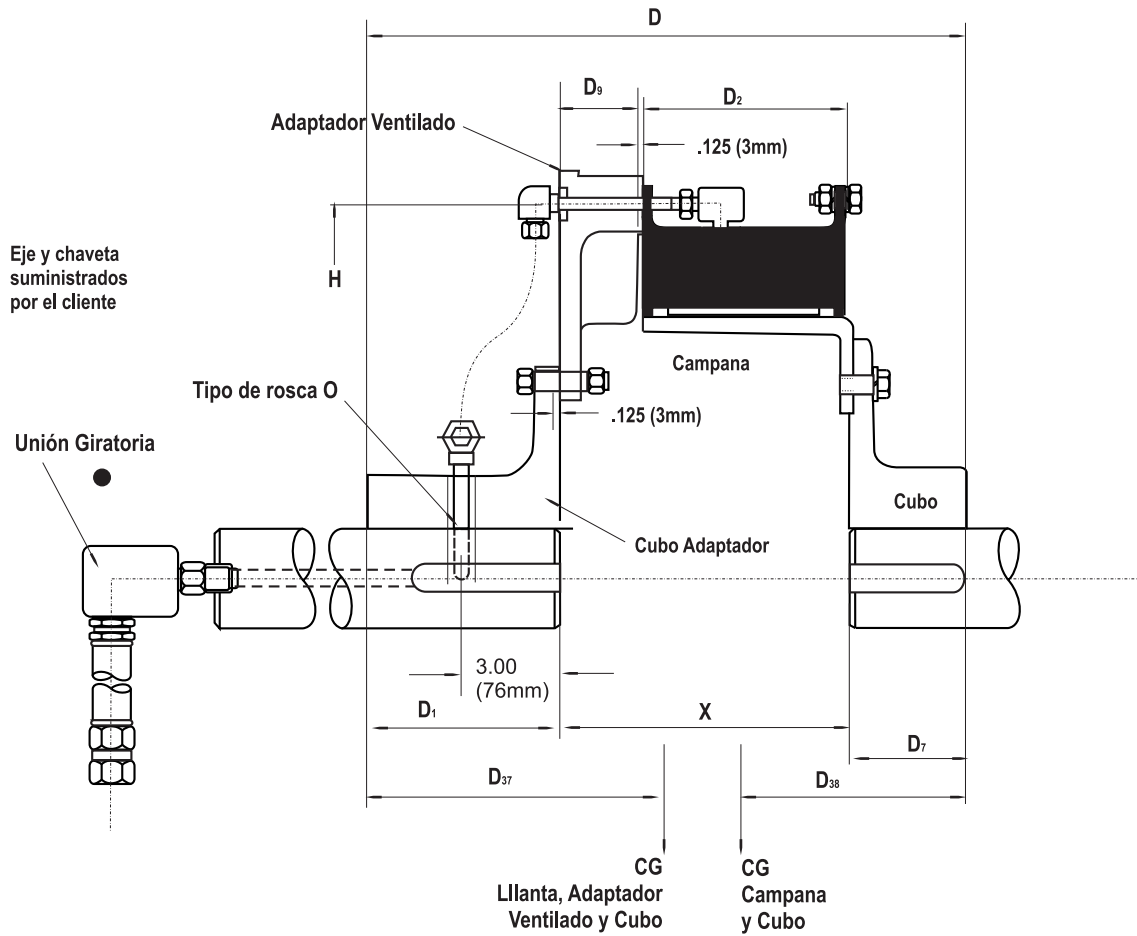

INGLES		lb.pulg @ 75 psi		lb ³	Dimensiones en pulgadas												Nº	Tamaño				
Tamaño	Nº de Parte	M. Torque Nomin.	Tamaño U.Girat.	Peso Total	mín		máx		mín		máx		D	D ₁	D ₂	D ₇	D ₉	D ₃₇	D ₃₈	H	O ⁴	X
					Eje Cubo Adapt.		Eje Cubo Adapt.															
					mín	máx	mín	máx														
11,5FKT500	216201	27000	B2	259	2.50	4.13	2.50	4.13	2.50	4.13	19.38	5.00	2.75	7.6	5.5	20.38	2	1/4 -18	9.38			
14FKT500	216202	39200	B2	379	2.75	5.00	2.75	5.00	2.75	5.00	20.88	5.75	2.75	8.2	5.8	24.63	2	3/8 -18	9.38			
16FKT600	216203	65000	B2	454	3.25	5.00	3.25	5.00	3.25	5.00	22.13	5.75	2.75	8.4	6.5	26.63	2	3/8 -18	10.63			
20FKT600	216204	93000	C2	616	3.75	5.50	3.75	5.50	3.75	5.50	23.63	6.50	2.75	8.9	7.0	30.63	2	3/8 -18	10.63			
24FKT650	216205	135000	C2	814	4.25	6.00	4.25	6.00	4.25	6.00	24.13	6.50	2.75	9.0	7.2	35.13	2	3/8 -18	11.13			
28FKT650	216206	182000	C2	1082	4.75	6.00	4.75	6.00	4.75	8.00	27.13	8.00	2.75	10.2	7.9	39.13	2	3/8 -18	11.13			
33FKT650	216207	255000	D2	1521	5.25	7.00	5.25	7.00	5.25	9.50	29.13	9.00	2.75	11.0	8.3	45.88	2	1/2 - 14	11.13			
37FKT650	216208	320000	D2	1726	5.50	7.00	5.50	7.00	5.50	9.50	29.13	9.00	2.75	11.0	8.4	49.88	2	1/2 - 14	11.13			
42FKT650	216209	380000	D2	2230	6.00	8.25	6.00	8.25	6.00	10.50	31.13	10.00	2.75	11.2	9.0	54.88	2	1/2 - 14	11.13			
11,5FKT500	216201	3050	B2	117	64	105	64	105	492	127	156	127	70	193	140	518	2	1/4 -18	238			
14FKT500	216202	4430	B2	172	70	127	70	127	530	146	156	146	70	208	174	626	2	3/8 -18	238			
16FKT600	216203	7346	B2	206	83	127	83	127	562	146	187	146	70	213	165	676	2	3/8 -18	270			
20FKT600	216204	10511	D2	279	95	140	95	140	600	165	187	165	70	226	178	776	2	3/8 -18	270			
24FKT650	216205	15258	C2	369	108	152	108	152	613	165	195	165	70	229	183	892	2	3/8 -18	283			
28FKT650	216206	20570	C2	490	121	152	121	203	689	203	195	203	70	259	201	994	2	3/8 -18	283			
33FKT650	216207	28821	D2	689	133	178	133	241	740	229	195	229	70	279	211	1165	2	1/2 - 14	283			
37FKT650	216208	36168	D2	782	140	178	140	241	740	229	195	229	70	279	213	1267	2	1/2 - 14	283			
42FKT650	216209	42949	D2	1011	152	210	152	267	791	254	195	254	70	284	229	1394	2	1/2 - 14	283			
SI	N-m @ 5.2 bar			lb ³	Dimensiones en milímetros												Nº	Nº	Tamaño			

* Los datos presentados en los catálogos son indicativos y sujetos a modificación sin previo aviso.



Disposición con Adaptador Ventilado - Datos Técnicos

Serie Angosta Dual 11,5 al 42

INGLES	lb	lb-ft ²	lb	lb-ft ²	lb	lb-ft ²	lb	lb-ft ²	lb	lb-ft ²
11,5FKT500	197	86	73	35	64	4	83	16	43	2
14FKT500	258	156	103	70	74	8	139	40	60	4
16FKT600	307	230	130	108	108	15	175	66	82	6
20FKT600	363	386	146	167	166	34	234	138	124	13
24FKT650	497	738	194	297	250	68	293	258	215	42
28FKT650	565	1074	219	424	324	119	348	472	292	85
33FKT650	784	2166	259	686	532	342	507	827	395	123
37FKT650	871	2800	321	1026	595	360	553	1172	528	240
42FKT650	980	3980	378	1550	769	608	662	1809	647	413
TAMAÑO	Peso	Wk ²	Peso	Wk ²	Peso	Wk ²	Peso	Wk ²	Peso	Wk ²
	Llanta		Adapt. Ventilado		Cubo Adaptador		Campana		Porta Campana	
	Peso	J	Peso	J	Peso	J	Peso	J	Peso	J
11,5FKT500	89	3.62	33	21.47	29	0.17	38	0.67	19	0.08
14FKT500	117	6.56	47	2.94	34	0.33	63	1.68	27	0.17
16FKT600	139	9.68	59	4.54	49	0.63	79	2.77	37	0.25
20FKT600	164	16.25	66	7.03	75	1.43	106	5.81	56	0.55
24FKT650	225	31.07	88	12.50	113	2.86	133	10.86	97	1.77
28FKT650	256	45.21	99	17.85	147	5.00	158	19.87	132	3.58
33FKT650	355	91.18	117	28.88	241	14.36	230	34.81	179	5.17
37FKT650	395	117.8	145	43.19	270	15.12	251	49.34	239	10.10
42FKT650	444	167.5	171	65.25	348	25.54	300	76.15	293	17.38
SI	Kg	Kg-m ²	Kg	Kg-m ²	Kg	Kg-m ²	Kg	Kg-m ²	Kg	Kg-m ²

TAMAÑO	N° de Parte				
	Llanta ⁷	Adaptador	Cubo Adaptador	Campana	Porta Campana
11,5FKT500	101006	216911	216631	216031	216331
14FKT500	101060	216912	216641	216041	216341
16FKT600	101109	216913	216651	216051	216351
20FKT600	101158	216914	216661	216061	216361
24FKT650	101208	216915	216671	216071	216371
28FKT650	101260	216916	216681	216081	216381
33FKT650	101303	216917	216691	216091	216391
37FKT650	101358	216918	216701	216101	216401
42FKT650	101402	216919	216711	216111	216411

* Los datos presentados en los catálogos son indicativos y sujetos a modificación sin previo aviso.

NOTAS:

- 1- Solicitar por n° de parte, no incluye unión giratoria ni manguera.
- 2- El torque indicado es dinámico, el torque estático es aproximadamente 25 % mayor. El torque en cada aplicación depende de la presión de aire y la velocidad.
- 3- Peso referido a mínimo Ø de eje. No incluye unión giratoria ni manguera.
- 4- Rosca NPT.
- 5- Referente a unión giratoria, ver información de montaje y dimensiones.
- 6- Peso referido a mínimo Ø de eje.
- 7- Referido al n° de parte básico únicamente.
Con la solicitud indicar el n° de entradas de aire y el tipo de conexión.

FKT - Aplicación Embrague
 Disposición con Adaptador Ventilado - Datos dimensionales
 Serie Angosta Dual 11,5 al 42

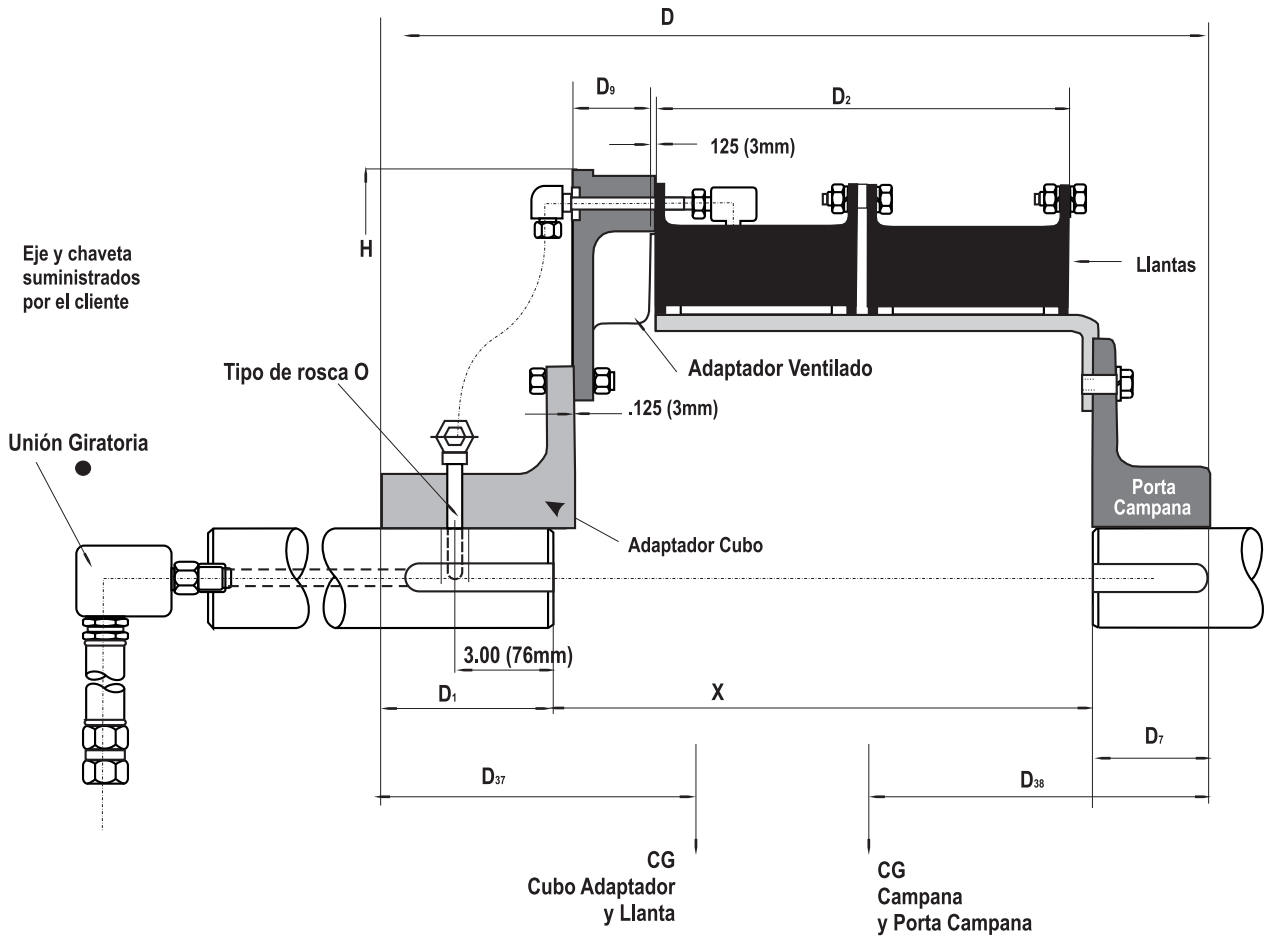

INGLES		lb.pulg @ 75 ps		lb ³	Dimensiones en pulgadas												
11,5FKT500	216221	54000	C2	460	3.00	4.00	28.75	5.75	12.75	7.00	2.75	10.9	9.4	20.38	2	1/4 - 18	16.00
14FKT500	216222	78400	C2	634	3.50	4.75	27.50	5.75	12.69	5.75	2.75	11.0	8.9	24.63	2	1/2-14	16.00
16FKT600	216223	130000	C2	802	4.25	5.00	31.56	6.50	15.19	6.50	2.75	12.4	9.8	26.63	2	1/2-14	18.56
20FKT600	216224	186000	C2	1033	4.75	6.00	32.56	7.00	15.19	7.00	2.75	12.2	9.7	30.63	2	1/2-14	18.56
24FKT650	216225	270000	D2	1449	5.25	7.50	34.31	7.50	15.94	7.50	2.75	12.6	9.7	35.13	2	1/2-14	19.31
28FKT650	216226	364000	D2	1748	5.75	8.50	35.31	8.00	15.94	8.00	2.75	12.8	9.9	39.13	2	1/2-14	19.31
33FKT650	216227	510000	R2	2477	6.50	9.00	38.38	9.50	15.94	9.50	2.75	13.8	11.0	45.88	2	3/4 - 14	19.38
37FKT650	216228	640000	R2	2868	7.00	9.50	39.38	10.00	15.94	10.00	2.75	14.2	11.2	49.88	2	3/4 - 14	19.38
42FKT650	216229	760000	R3	3436	7.50	10.50	41.38	11.00	15.94	11.00	2.75	14.7	11.5	54.88	2	3/4 - 14	19.38
Tamaño	N° de Parte	M. Torque Nomin.	Tamaño U.Girat.	Peso Total	Rango de eje		D	D ₁	D ₂	D ₇	D ₉	D ₃₇	D ₃₈	H	N° Tamaño		X
					mín	máx									O	4	
					mín	máx									N°	Tamaño	
11,5FKT500	216221	6100	C2	208	76	102	730	146	324	178	70	276	239	518	2	1/4 - 18	406
14FKT500	216222	8860	C2	287	89	121	699	146	322	146	70	279	226	626	2	1/2-14	406
16FKT600	216223	14698	C2	363	108	127	802	165	386	165	70	314	249	676	2	1/2-14	471
20FKT600	216224	21020	C2	468	121	152	827	178	386	178	70	309	246	778	2	1/2-14	471
24FKT650	216225	30516	D2	657	133	191	871	191	405	191	70	320	246	892	2	1/2-14	490
28FKT650	216226	41141	D2	793	146	216	897	203	405	203	70	325	251	994	2	1/2-14	490
33FKT650	216227	57642	R2	1123	165	229	975	241	405	241	70	350	279	1165	2	3/4 - 14	492
37FKT650	216228	72336	R2	1300	178	241	1000	254	405	254	70	361	284	1265	2	3/4 - 14	492
42FKT650	216229	85900	R3	1558	191	267	1051	279	405	279	70	373	292	1394	2	3/4 - 14	492
SI		N-m @ 5.2 bar		kg ³	Dimensiones en milímetros												

* Los datos presentados en los catálogos son indicativos y sujetos a modificación sin previo aviso.



INGLES	lb	lb-ft ²	lb	lb-ft ²	lb	lb-ft ²	lb	lb-ft ²
11,5FKT500	96	43	70	19	46	9	35	2
14FKT500	128	78	102	35	66	19	65	4
16FKT600	151	115	139	50	94	35	62	4
20FKT600	179	193	224	122	139	78	95	9
24FKT650	246	369	260	174	178	148	124	19
28FKT650	280	537	514	534	231	269	240	59
33FKT650	392	1083	716	811	312	486	347	93
37FKT650	433	1400	940	1404	340	691	398	159
42FKT650	485	1990	1284	2106	424	110	545	243
TAMAÑO	Peso	Wk ²	Peso	Wk ²	Peso	Wk ²	Peso	Wk ²
	Llanta		Porta Llanta		Campana		Cubo Porta Campana	
	Peso	J	Peso	J	Peso	J	Peso	J
11,5FKT500	43	1.81	32	0.80	21	0.38	16	0.08
14FKT500	58	3.28	46	1.47	30	0.80	29	0.17
16FKT600	68	4.84	63	2.10	43	1.47	28	0.17
20FKT600	81	8.12	101	5.13	63	3.28	43	0.38
24FKT650	111	15.53	118	7.32	81	6.23	56	0.80
28FKT650	127	22.60	233	22.48	105	11.32	109	2.48
33FKT650	178	45.59	324	34.14	141	20.46	157	3.91
37FKT650	196	58.94	426	59.10	154	29.09	180	6.69
42FKT650	220	83.77	582	88.66	192	46.31	247	10.23
SI	Kg	Kg-m ²	Kg	Kg-m ²	Kg	Kg-m ²	Kg	Kg-m ²

TAMAÑO	N° de Parte			
	Llanta 10	Porta Llanta	Campana	Cubo Porta Campana
11,5FKT500	101002	216630	216030	216330
14FKT500	101050	216640	216040	216340
16FKT600	101102	216650	216050	216350
20FKT600	101152	216660	216060	216360
24FKT650	101202	216670	216070	216370
28FKT650	101252	216680	216080	216380
33FKT650	101300	216690	216090	216390
37FKT650	101350	216700	216100	216400
42FKT650	101400	216710	216110	216410

* Los datos presentados en los catálogos son indicativos y sujetos a modificación sin previo aviso.

NOTAS:

- 1- Solicitar por n° de parte, no incluye unión giratoria ni manguera.
- 2- El torque indicado es dinámico, el torque estático es aproximadamente 25 % mayor. El torque en cada aplicación depende de la presión de aire y la velocidad.
- 3- Peso referido a mínimo Ø de eje. No incluye unión giratoria ni manguera.
- 4 - $M(\text{pulg}) = 0,268 (H/2 - \text{radio de eje}) + 0,34$ $M(\text{mm.}) = 6,8 (H/2 - \text{radio de eje}) + 8,7$
- 5- Rosca NPT.
- 6- Para agujeros de 11 mm. (0,44 pulg) no requiere conector.
- 7- Referente a unión giratoria, ver información de montaje y dimensiones.
- 8- Para otros modelos ver porta llanta FKT en configuración de este catálogo.
- 6- Peso referido a mínimo Ø de eje.
- 7- Referido al n° de parte básico únicamente. Con la solicitud indicar el n° de entradas de aire y el tipo de conexión.

FKT - Aplicación Embrague
Disposición Montaje Estándar - Datos Dimensionales
Serie Angosta 11,5 al 42

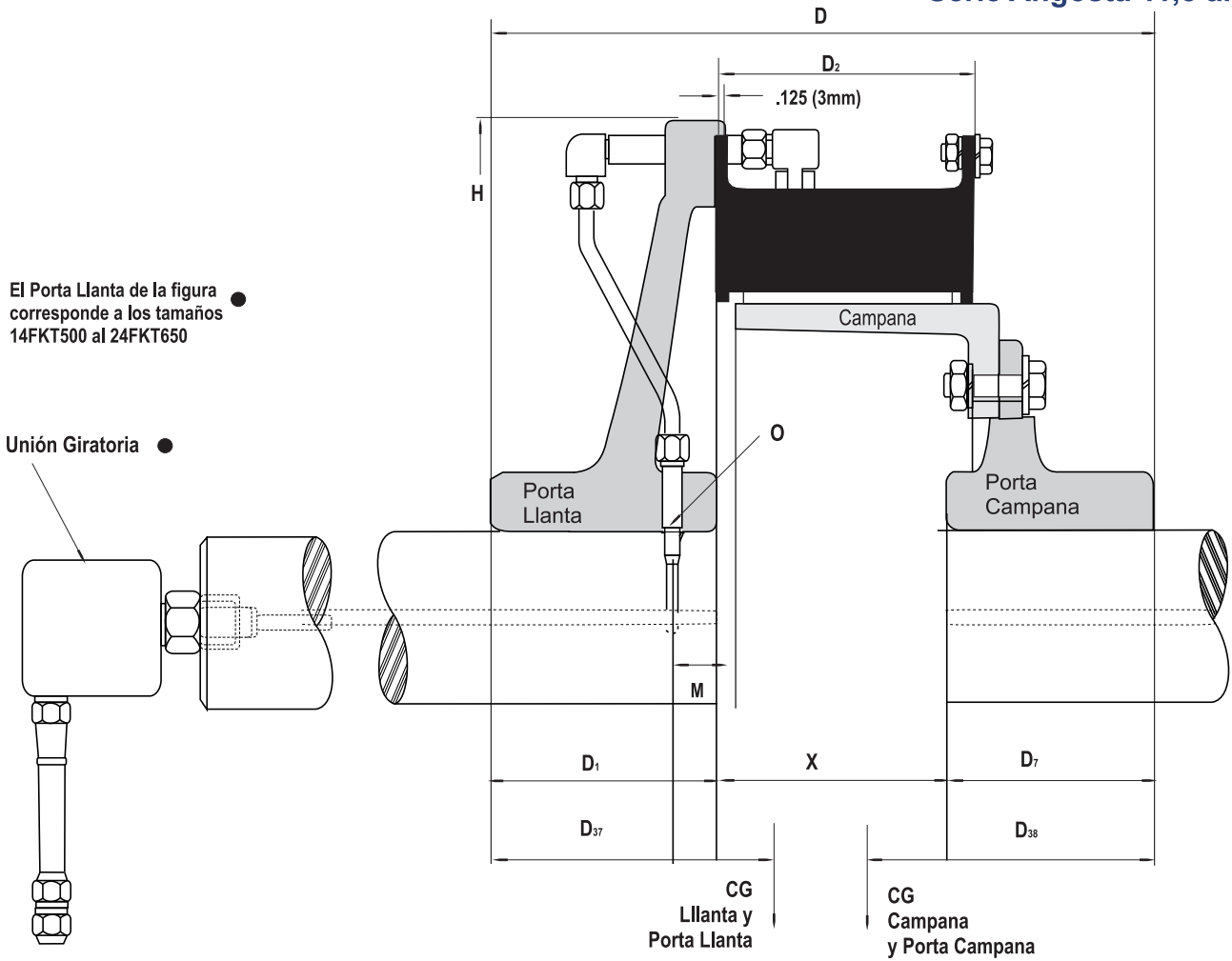

INGLES		lb.pulg @ 75 psi		lb ³	Dimensiones en pulgadas											
11,5FKT500	216001	27000	B2	247	2.50	4.13	16.09	434	6.13	5.00	5.3	5.5	20.00	⁴	⁶	6.75
14FKT500	216002	39200	B2	361	2.75	5.00	18.06	5.50	6.13	5.75	6.0	5.8	24.00	1.44	3/8- 18	6.81
16FKT600	216003	65000	B2	446	3.25	5.00	19.31	5.50	7.38	5.75	6.2	6.5	26.00	1.44	3/8- 18	8.06
20FKT600	216004	93000	C2	637	3.75	5.50	20.56	6.00	7.38	6.50	6.0	6.9	30.00	1.44	3/8- 18	8.06
24FKT650	216005	135000	C2	808	4.25	6.00	21.56	6.50	7.69	6.50	6.6	7.2	34.63	1.44	3/8- 18	8.56
28FKT650	216006	182000	C2	1265	4.75	8.00	24.56	8.00	7.69	8.00	6.9	7.9	38.63	5.00	1/2-14	8.56
33FKT650	216007	255000	D2	1767	5.25	9.50	26.56	9.00	7.69	9.00	7.5	8.3	45.25	5.00	1/2-14	8.56
37FKT650	216008	320000	D2	2111	5.50	9.50	27.56	10.00	7.69	9.00	7.9	8.4	49.25	6.00	1/2-14	8.56
42FKT650	216009	380000	D2	2738	6.00	10.50	29.56	11.00	7.69	10.00	8.2	9.0	54.25	6.00	1/2-14	8.56
Tamaño	N° de Parte ¹	M. Torque Nomin. ²	Tamaño U. Girat.	Peso Total	Rango de eje		D	D ₁	D ₂	D ₇	D ₃₇	D ₃₄	H	M	O ⁶	X
					min	máx										
					min	máx										
11,5FKT500	216001	3050	B2	112	64	105	409	110	156	127	135	140	508	⁴	⁶	171
14FKT500	216002	4430	B2	164	70	127	459	140	156	146	152	147	610	37	3/8- 18	173
16FKT600	216003	7346	B2	202	83	127	490	140	187	146	157	165	660	37	3/8- 18	205
20FKT600	216004	10511	C2	289	95	140	522	152	187	165	152	175	762	37	3/8- 18	205
24FKT650	216005	15258	C2	366	108	152	548	165	195	165	168	183	880	37	3/8- 18	217
28FKT650	216006	20570	C2	573	121	203	624	203	195	203	175	201	981	127	1/2-14	217
33FKT650	216007	28821	D2	801	133	241	675	229	195	229	191	211	1149	127	1/2-14	217
37FKT650	216008	36168	D2	957	140	241	700	254	195	229	201	213	1251	152	1/2-14	217
42FKT650	216009	42949	D2	1241	152	267	751	279	195	254	208	229	1378	152	1/2-14	217
SI		N-m @ 5.2 bar		kg ³	Dimensiones en milímetros											

* Los datos presentados en los catálogos son indicativos y sujetos a modificación sin previo aviso.



INGLES	lb	lb-ft ²	lb	lb-ft ²	lb	lb-ft ²	lb	lb-ft ²
11,5FKT500	197	86	71	19	83	16	43	2
14FKT500	258	156	102	35	139	40	60	4
16FKT600	307	230	236	111	175	66	82	6
20FKT600	363	386	295	167	234	138	124	13
24FKT650	497	736	408	285	293	258	215	42
28FKT650	565	1074	554	474	348	472	292	85
33FKT650	784	2166	802	965	507	827	395	123
37FKT650	871	2800	981	1356	553	1172	528	240
42FKT650	980	3980	1116	1868	662	1809	647	413
TAMAÑO ⁹	Peso	Wk ²	Peso	Wk ²	Peso	Wk ²	Peso	Wk ²
	Llanta		Porta Llanta		Campana		Cubo Porta Campana	
	Peso	J	Peso	J	Peso	J	Peso	J
11,5FKT500	89	3.62	32	0.80	38	0.67	19	0.08
14FKT500	117	6.56	46	1.47	63	1.68	27	0.17
16FKT600	139	9.68	107	4.67	79	2.77	37	0.25
20FKT600	164	16.25	134	7.03	106	5.81	56	0.55
24FKT650	225	31.07	185	11.99	133	10.86	97	1.76
28FKT650	256	45.21	251	19.95	158	19.87	132	3.57
33FKT650	355	91.18	363	40.62	230	34.81	179	5.17
37FKT650	395	117.8	444	57.08	251	49.34	239	10.08
42FKT650	444	167.5	506	78.64	300	76.15	293	17.35
SI	Kg	Kg-m ²	Kg	Kg-m ²	Kg	Kg-m ²	Kg	Kg-m ²

TAMAÑO	N° de Parte			
	Llanta ¹⁰	Porta Llanta	Campana	Cubo Porta Campana
11,5FKT500	101006	216631	216031	216331
14FKT500	101060	216641	216041	216341
16FKT600	101109	216651	216051	216351
20FKT600	101158	216661	216061	216361
24FKT650	101208	216671	216071	216371
28FKT650	101260	216681	216081	216381
33FKT650	101303	216691	216091	216391
37FKT650	101358	216701	216101	216401
42FKT650	101402	216711	216111	216411

* Los datos presentados en los catálogos son indicativos y sujetos a modificación sin previo aviso.

NOTAS:

- 1- Solicitar por n° de parte, no incluye unión giratoria ni manguera.
- 2- El torque indicado es dinámico, el torque estático es aproximadamente 25 % mayor. El torque en cada aplicación depende de la presión de aire y la velocidad.
- 3- Peso referido a mínimo Ø de eje. No incluye unión giratoria ni manguera.
- 4 - $M(\text{pulg}) = 0,268 (H/2 - \text{radio de eje}) + 0,34$ $M(\text{mm.}) = 6,8 (H/2 - \text{radio de eje}) + 8,7$
- 5- Rosca NPT.
- 6- Para agujeros de 11 mm. (0,44 pulg) no requiere conector.
- 7- Referente a unión giratoria, ver información de montaje y dimensiones.
- 8- Para otros modelos ver porta llanta FKT en configuración de este catálogo.
- 9- Peso referido a mínimo Ø de eje.
- 10- Referido al n° de parte básico únicamente. Con la solicitud indicar el n° de entradas de aire y el tipo de conexión.

FKT - Aplicación Embrague
Disposición Montaje Estándar - Datos dimensionales
Serie Angosta Dual 11,5 al 42

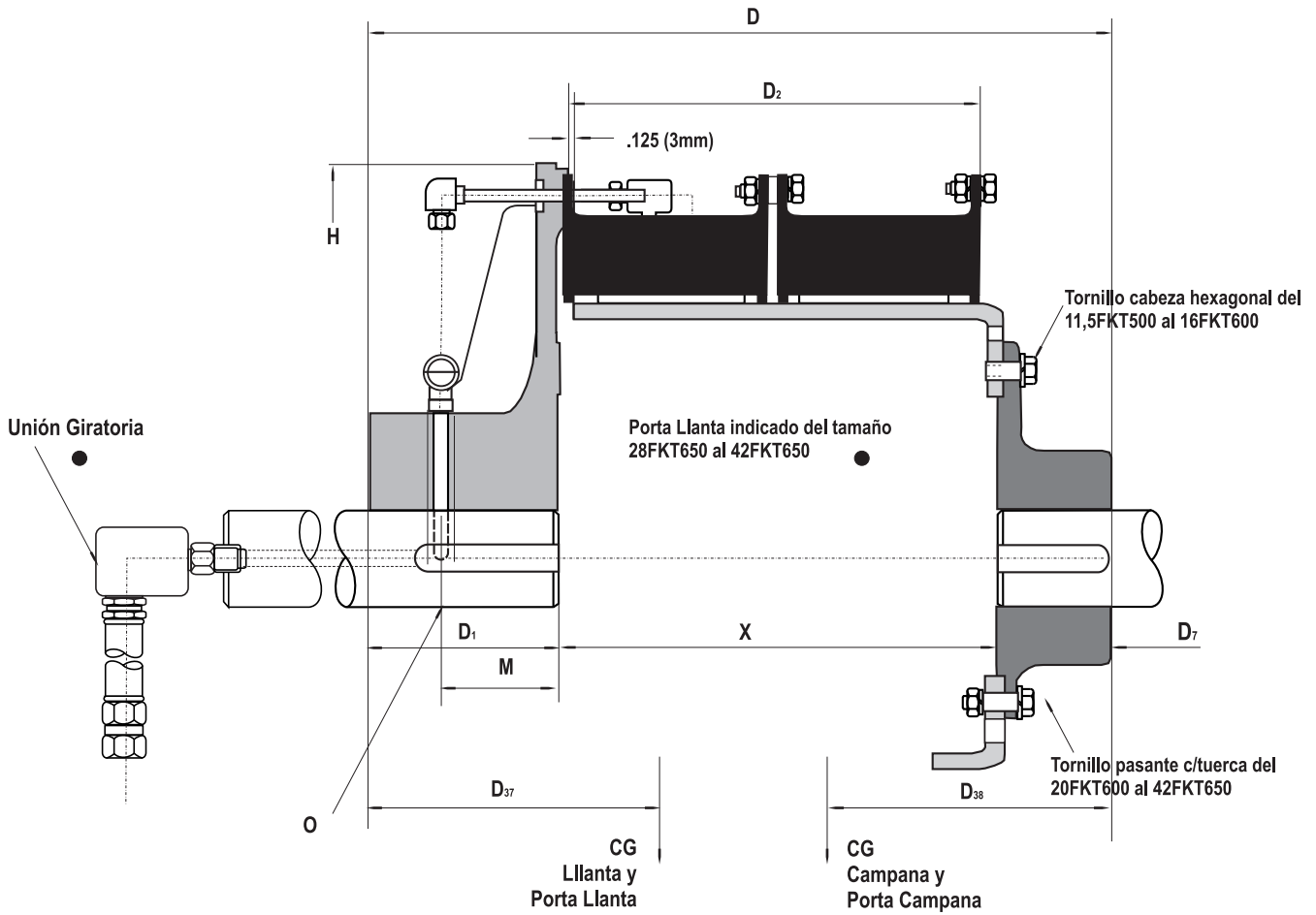

INGLES		lb.pulg @ 75 psi		lb ³	Dimensiones en pulgadas											
Tamaño	N° de Parte	M. Torque Nomin.	Tamaño U.Girat.	Peso Total	Rango de eje		D	D ₁	D ₂	D ₇	D ₃₇	D ₃₈	H	M	O	X
					mín	máx										
					mín	máx										
11,5FKT500	216001	54000	C2	394	3.00	4.00	25.22	4.84	12.75	7.00	8.8	9.4	20.00	⁴	⁶	13.38
14FKT500	216002	78400	C2	559	3.50	4.75	24.69	5.50	12.69	5.75	9.2	8.9	24.00	1.44	1/2-14	13.44
16FKT600	216003	130000	C2	800	4.25	6.00	27.94	5.50	15.19	6.50	9.6	9.7	26.00	4.00	1/2-14	15.94
20FKT600	216004	186000	C2	1016	4.75	6.00	29.94	7.00	15.19	7.00	10.2	9.7	30.00	5.00	1/2-14	15.94
24FKT650	216005	270000	D2	1413	5.25	7.50	31.69	7.50	15.94	7.50	10.1	9.9	34.63	5.00	3/4-14	16.69
28FKT650	216006	364000	D2	1759	5.75	8.50	32.69	8.00	15.94	8.00	10.7	11.0	38.63	5.00	3/4-14	16.69
33FKT650	216007	510000	R2	2488	6.50	9.00	35.25	9.00	15.94	9.50	11.1	11.2	45.25	5.00	3/4-14	16.75
37FKT650	216008	640000	R2	2933	7.00	9.50	36.75	10.00	15.94	10.00	11.8	11.5	49.25	6.00	3/4-14	16.75
42FKT650	216009	760000	R3	3405	7.50	10.50	38.75	11.00	15.94	11.00	8.6	9.8	54.25	6.00	3/4-14	16.75
11,5FKT500	216001	6100	C2	178	76	102	641	123	324	178	224	239	508	⁴	⁶	340
14FKT500	216002	8860	C2	253	89	121	627	140	322	146	234	226	610	37	1/2-14	341
16FKT600	216003	14690	C2	362	108	152	710	140	386	165	244	246	660	102	1/2-14	405
20FKT600	216004	21020	C2	460	121	152	760	178	405	178	259	246	762	127	1/2-14	405
24FKT650	216005	30516	D2	640	133	191	805	191	405	191	257	251	880	127	3/4-14	424
28FKT650	216006	41141	D2	797	146	216	830	203	405	203	272	279	981	127	3/4-14	424
33FKT650	216007	57642	R2	1128	165	229	895	229	405	241	282	284	1149	127	3/4-14	425
37FKT650	216008	72336	R2	1330	178	241	933	254	405	254	300	292	1251	152	3/4-14	425
42FKT650	216009	85900	R3	1544	191	267	984	279	405	279	218	249	1378	152	3/4-14	425
SI		N-m @ 5.2 bar		kg ³	Dimensiones en milímetros											

* Los datos presentados en los catálogos son indicativos y sujetos a modificación sin previo aviso.



Disposición Montaje Estándar - Datos Técnicos

Serie Ancha 14 al 66

INGLES	lb	lb-ft ²	lb	lb-ft ²	lb	lb-ft ²	lb	lb-ft ²
14FKT1000	213	127	205	79	122	35	70	5
16FKT1000	240	212	264	113	98	38	97	9
20FKT1000	282	309	295	167	169	112	150	21
24FKT1000	378	552	408	285	225	192	215	44
28FKT1000	431	826	554	574	295	350	297	82
32FKT1000	624	1570	727	781	371	559	407	127
38FKT1200	684	2330	1002	1502	552	1214	521	236
42FKT1200	895	3670	1116	1868	582	1567	677	378
46FKT1200	980	4830	1504	2968	729	2357	813	577
52FKT1200	1192	7285	2579	5087	852	3552	1125	1000
51FKT1600	1934	10580	2621	6706	890	4145	1475	1150
60FKT1600	2450	20532	4096	13346	1640	8810	2526	3034
66FKT1600	2630	24850	6500	19360	1905	15070	4940	6760
TAMAÑO	Peso	Wk ²	Peso	Wk ²	Peso	Wk ²	Peso	Wk ²
	Llanta		Porta Llanta		Campana		Cubo Porta Campana	
	Peso	J	Peso	J	Peso	J	Peso	J
14FKT1000	96	5.34	93	3.32	55	1.47	32	0.21
16FKT1000	109	8.92	120	4.75	44	1.60	44	0.38
20FKT1000	128	13	134	7.03	77	4.72	68	0.88
24FKT1000	171	23.23	185	11.99	102	8.08	97	1.85
28FKT1000	195	34.77	251	24.16	134	14.74	135	3.45
32FKT1000	283	66.09	329	32.88	168	23.53	184	5.34
38FKT1200	310	98.09	454	63.23	250	51.11	236	9.93
42FKT1200	405	154.5	506	78.64	264	65.97	307	15.91
46FKT1200	444	203.3	682	124.9	330	99.23	368	24.29
52FKT1200	541	306.6	1169	214.1	386	149.2	510	42
51FKT1600	877	445.4	1188	282.3	403	174.5	669	48.41
60FKT1600	1111	864.3	1857	561.8	743	370	1145	127.7
66FKT1600	1193	1046	2948	815	864	634.4	2240	284.5
SI	Kg	Kg-m ²	Kg	Kg-m ²	Kg	Kg-m ²	Kg	Kg-m ²

NOTAS:

- 1- Solicitar por n° de parte, no incluye unión giratoria ni manguera.
- 2- El torque indicado es dinámico, el torque estático es aproximadamente 25 % mayor. El torque en cada aplicación depende de la presión de aire y la velocidad.
- 3- Peso referido a mínimo Ø de eje. No incluye unión giratoria ni manguera.
- 4- Rosca NPT.
- 5- El porta llanta está construido en dos partes: un cubo y un plato adaptador.
- 6- Referente a unión giratoria, ver información de montaje y dimensiones.
- 7- Para otros modelos ver porta llanta FKT en configuración de este catálogo.
- 8- Peso referido a mínimo Ø de eje.
- 9- Referido al n° de parte básico únicamente. Con la solicitud indicar el n° de entradas de aire y el tipo de conexión.

TAMAÑO	N° de Parte			
	Llanta 10	Porta Llanta	Campana	Porta Campana
14FKT1000	102030	216720	216120	216420
16FKT1000	102000	216730	216130	216430
20FKT1000	102050	216740	216140	216440
24FKT1000	102100	216750	216150	216450
28FKT1000	102150	216760	216160	216460
32FKT1000	102200	216770	216170	216470
38FKT1200	102250	216780	216180	216480
42FKT1200	102300	216790	216180	216490
48FKT1200	102350	216800	216200	216500
52FKT1200	102400	216810	216210	216510
51FKT1600	102450	216820	216220	216520
60FKT1600	102500	216830	216230	216530
66FKT1600	102550		216240	216540

* Los datos presentados en los catálogos son indicativos y sujetos a modificación sin previo aviso.

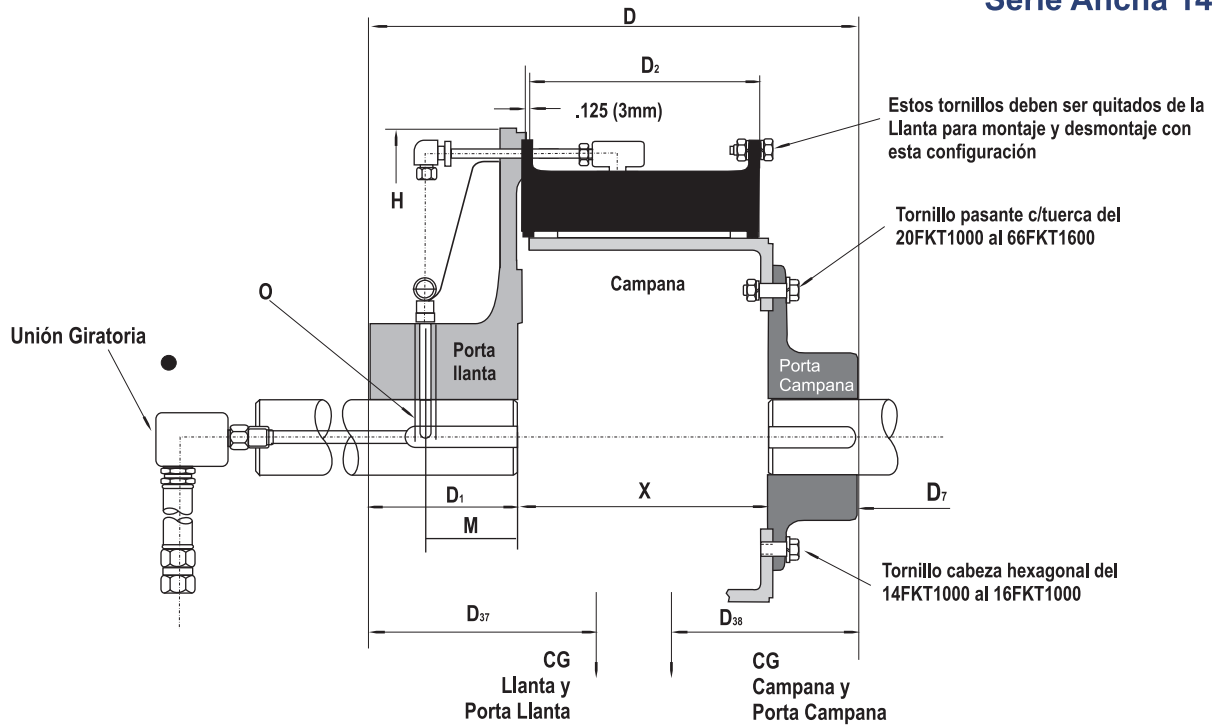

INGLES		lb.pulg @ 75 psi		lb ³	Dimensiones en pulgadas												
Tamaño	N° de Parte	M. Torque Nomín.	Tamaño U.Girat.	Peso Total	Rango de eje		D	D ₁	D ₂	D ₇	D ₃₇	D ₃₄	H	M	O	X	
					mín	máx											
14FKT1000	217001	85000	C2	610	3.63	5.00	24.38	5.50	11.56	7.00	7.0	8.8	24.00	4.00	3/8-18	11.88	
16FKT1000	217002	114000	C2	699	3.88	6.00	22.88	5.50	11.56	5.50	6.7	6.6	26.00	4.00	3/8-18	11.88	
20FKT1000	217003	161000	C2	869	4.50	6.25	25.88	7.00	11.56	7.00	7.5	8.1	30.00	5.00	3/8-18	11.88	
24FKT1000	217004	219000	D2	1226	5.00	8.00	26.88	7.50	11.56	7.50	7.9	8.3	34.63	5.00	1/2-14	11.88	
28FKT1000	217005	415000	D2	1577	5.50	8.50	27.88	8.00	11.56	8.00	8.0	8.7	38.63	5.00	1/2-14	11.88	
32FKT1000	217006	296000	R2	2129	6.00	9.00	30.44	9.00	11.63	9.50	9.1	9.6	44.50	5.00	1/2-14	11.94	
38FKT1200	217007	680000	R3	2759	7.25	9.25	34.13	10.00	13.75	10.00	9.5	10.6	50.00	6.00	1/2-14	14.13	
42FKT1200	217008	819000	R3	3270	7.50	10.00	36.13	11.00	13.75	11.00	10.6	11.0	54.25	6.00	1/2-14	14.13	
46FKT1200	217009	950000	R3	4026	8.00	10.00	36.13	11.00	13.75	11.00	10.0	11.3	61.00	6.00	1/2-14	14.13	
52FKT1200	217010	1215000	R3	5748	8.75	11.00	39.63	12.50	14.25	12.50	10.3	12.3	67.75	7.00	3/4-14	14.63	
51FKT1600	217011	1610000	R3	6920	9.50	12.50	48.88	15.00	18.25	15.00	13.9	14.3	67.75	7.00	3/4-14	18.88	
60FKT1600	217012	2183000	R3	10750	10.50	18.00	50.75	16.00	18.50	16.00	14.2	15.2	77.75	7.00	1-11 1/2	18.75	
66FKT1600		2800000	R3	16200	11.25	18.50	60.25	5	18.50	20.00	18.4	15.3	82.50	9.00	1-11 1/2	20.25	
14FKT1000	217001	9607	C2	276	92	127	619	140	294	178	178	224	610	102	3/8-18	302	
16FKT1000	217002	12884	C2	317	99	152	581	140	294	140	170	168	660	102	3/8-18	302	
20FKT1000	217003	18197	C2	406	114	159	657	178	294	178	191	206	762	127	3/8-18	302	
24FKT1000	217004	24752	D2	556	127	203	683	191	294	191	201	211	880	127	1/2-14	302	
28FKT1000	217005	33455	D2	715	140	216	708	203	294	203	203	221	981	127	1/2-14	302	
32FKT1000	217006	46905	R2	965	152	229	773	229	295	241	231	244	1130	127	1/2-14	303	
38FKT1200	217007	76857	R3	1251	184	235	867	254	349	254	241	269	1270	152	1/2-14	359	
42FKT1200	217008	92567	R3	1483	191	254	918	279	349	279	269	279	1378	152	1/2-14	359	
46FKT1200	217009	107373	R3	1826	203	254	918	279	349	279	254	287	1549	152	1/2-14	359	
52FKT1200	217010	137325	R3	2607	222	279	1007	318	362	318	262	312	1721	178	3/4-14	372	
51FKT1600	217011	181970	R3	3138	241	318	1242	381	464	381	353	363	1721	178	3/4-14	480	
60FKT1600	217012	246733	R3	4876	267	457	1289	406	470	406	361	386	1975	178	1-11 1/2	476	
66FKT1600		316470	R3	7348	286	470	1530	5	470	508	467	389	2096	229	1-11 1/2	514	
SI	N-m @ 5.2 bar			kg ³	Dimensiones en milímetros												

* Los datos presentados en los catálogos son indicativos y sujetos a modificación sin previo aviso.

Disposición Montaje Estándar - Datos Técnicos

Serie Ancha Dual 16 al 66

TAMAÑO	N de Parte				
	Llanta 9	Porta Llanta	Camp. Macho	Camp. Hembra	Cubo Porta Campana
16FKT1000	102008	216731	216140	216141	216431
20FKT1000	102058	216741	216150	216151	216441
24FKT1000	102101	216751	216160	216161	216451
28FKT1000	102158	216761	216170	216171	216461
32FKT1000	102208	216771	216180	216181	216471
38FKT1000	102258	216781	216190	216191	216481
42FKT1200	102308	216791	216200	216201	216491
46FKT1200	102358	216801	216210	216211	216501
52FKT1200	102408	216811	216220	216221	216511
51FKT1600	102458	216821	216230	216231	216521
60FKT1600	102508	216831	216240	216241	216531
66FKT1600	102558	216841	216250	216251	216541

INGLES	lb	lb-ft²	lb	lb-ft²	lb	lb-ft²	lb	lb-ft²	lb	lb-ft²
16FKT1000	430	380	264	113	98	38	94	37	94	37
20FKT1000	568	618	333	197	169	112	164	106	164	106
24FKT1000	756	1104	442	312	225	192	215	186	215	186
28FKT1000	862	1652	680	597	295	350	282	338	282	338
32FKT1000	1248	3140	967	932	371	559	352	537	352	537
38FKT1200	1368	4660	1350	1625	552	1214	530	1173	530	1173
42FKT1200	1790	7340	1763	2445	582	1567	550	1510	550	1510
46FKT1200	1960	9660	1855	3577	729	2357	700	2276	700	2276
52FKT1200	2384	14570	2854	5277	852	3552	820	3425	820	3425
51FKT1600	3868	21160	3640	7610	890	4145	860	4035	860	4035
60FKT1600	4900	41064	5402	14489	1640	8810	1590	8575	1590	8575
66FKT1600	5260	49700	8020	21750	1905	15070	1770	14340	1770	14340

TAMAÑO 8	Peso	Wk²	Peso	Wk²	Peso	Wk²	Peso	Wk²	Peso	Wk²
	Llanta		Porta Llanta		Campana Macho		Campana Hembra		Cubo Porta Campana	
	Peso	J	Peso	J	Peso	J	Peso	J	Peso	J
16FKT1000	195	15.96	120	4.75	44	1.60	43	1.55	90	0.80
20FKT1000	257	26.01	151	8.29	77	4.70	74	4.58	92	1.34
24FKT1000	342	46.47	200	13.10	102	8.08	97	7.83	123	2.10
28FKT1000	390	69.54	308	25.13	134	14.74	128	14.23	168	4.16
32FKT1000	566	132.1	438	39.23	168	23.53	159	22.60	260	7.78
38FKT1200	620	196.1	612	68.41	250	51.11	240	49.38	365	15.49
42FKT1200	811	309	799	102.9	264	65.97	249	63.57	559	27.49
46FKT1200	889	406.6	840	150.5	330	99.23	317	95.82	596	36.03
52FKT1200	1080	613.3	1293	222.1	386	149.5	371	144.1	817	63.73
51FKT1600	1754	890.8	1649	320.3	403	174.5	390	169.8	1044	83.90
60FKT1600	2222	1728	2447	609.9	743	370.9	720	361	1879	209.1
66FKT1600	2385	2092	3633	915.6	864	634.4	802	603	2925	384.7

* Los datos presentados en los catálogos son indicativos y sujetos a modificación sin previo aviso.

NOTAS:

- 1- Solicitar por n° de parte. No incluye unión giratoria ni manguera.
- 2- El torque indicado es dinámico, el torque estático es aproximadamente 25 % mayor. El torque en cada aplicación depende de la presión de aire y la velocidad.
- 3- Peso referido a mínimo Ø de eje. No incluye unión giratoria ni manguera.
- 4- Rosca NPT.
- 5- El porta llanta está construido en dos partes: un cubo y un plato adaptador.
- 6- Referente a unión giratoria, ver información de montaje y dimensiones.
- 7- Para otros modelos ver porta llanta FKT en configuración de este catálogo.
- 8- Datos referidos a agujero mínimo.
- 9- Referido al n° de parte únicamente. Con la solicitud indicar el n° de entradas de aire y el tipo de conexión.



FKT - Aplicación Embrague
Disposición Montaje Estándar - Datos Dimensionales
Serie Ancha Dual 16 al 66

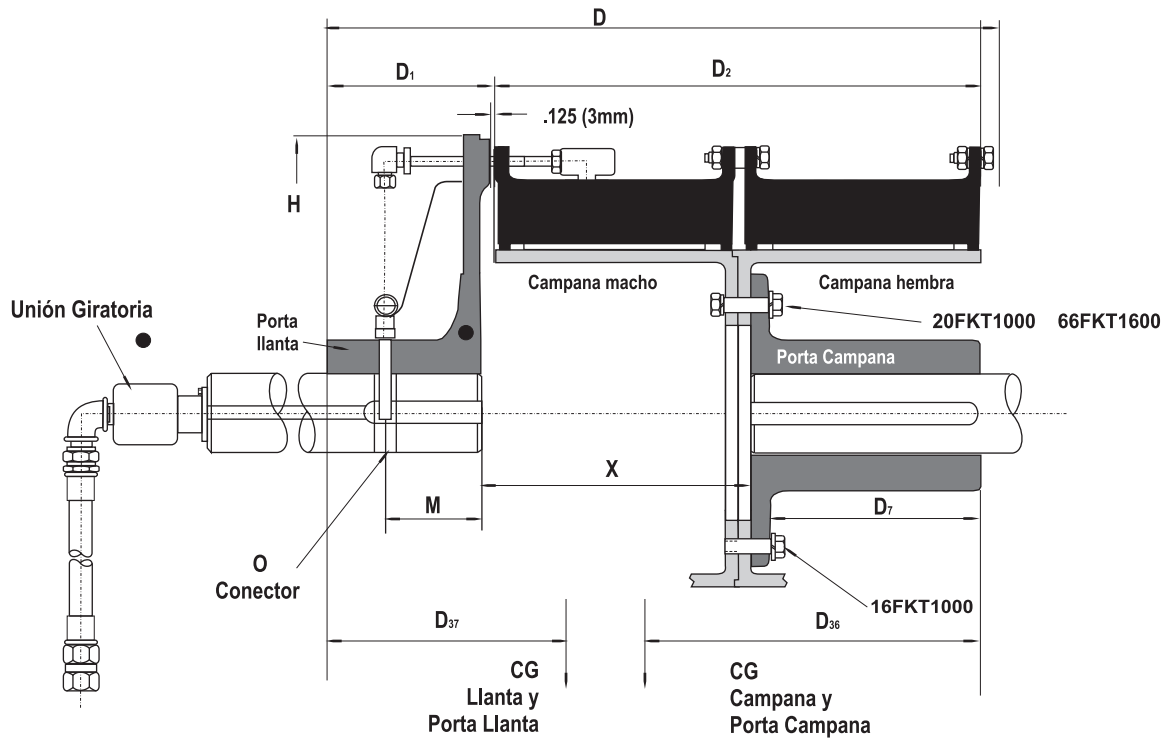

INGLES		lb.pulg @ 75 psi		lb ³	Dimensiones en pulgadas											
16FKT1000	217102	228000	R1	1085	5.00	6.00	32.00	8.00	23.69	10.00	14.0	13.8	26.00	4.00	1/2-14	12.75
20FKT1000	217103	322000	R2	1440	5.50	6.50	33.59	9.50	23.69	9.50	15.3	14.8	30.00	5.00	1/2-14	12.75
24FKT1000	217104	438000	R2	1910	6.25	7.25	33.39	9.31	23.69	9.50	15.1	15.0	34.63	5.00	3/4- 14	12.75
28FKT1000	217105	592000	R3	2490	6.75	8.00	34.08	10.00	23.69	10.00	14.5	15.3	38.63	5.00	3/4- 14	12.75
32FKT1000	217106	830000	R3	3510	7.75	10.50	36.20	12.00	23.81	12.00	16.5	15.9	44.50	5.00	3/4- 14	12.81
38FKT1200	217107	1360000	R4	4610	9.00	11.00	41.53	13.00	28.06	13.00	17.0	18.0	50.00	6.00	3/4- 14	15.00
42FKT1200	217108	1638000	R4	5920	9.50	11.75	45.53	17.00	28.06	17.00	20.0	19.7	54.25	6.00	3/4- 14	15.13
46FKT1200	217109	1900000	R4	6560	10.00	12.50	45.61	17.00	28.06	17.00	20.3	20.8	61.00	6.00	3/4- 14	15.25
52FKT1200	217110	2430000	R4	8715	10.75	14.00	46.61	17.00	29.06	17.00	19.5	19.9	67.75	7.00	1-11 1/2	15.75
51FKT1600	217111	3220000	R4	11560	12.00	15.50	57.61	20.00	37.06	20.00	27.0	23.0	67.75	7.00	1-11 1/2	20.00
60FKT1600	217112	4366000	R4	17675	13.25	20.00	62.17	24.00	37.56	24.00	27.8	26.0	77.75	7.00	1 1/4 11 1/2	20.38
66FKT1600		5600000	R4	22960	15.00	22.00	82.00	5	37.00	30.00	24.0	22.0	82.50	9.00	1 1/4 11 1/2	22.00
Tamaño	N° de Parte	M. Torque Nomin.	Tamaño U.Girat.	Peso Total	Rango de eje		D	D ₁	D ₂	D ₇	D ₃₇	D ₃₆	H	M	O	X
					mín	máx										
16FKT1000	217002	25800	R1	492	127	152	813	203	602	254	356	351	660	102	1/2-14	324
20FKT1000	217003	36400	R2	652	140	165	853	241	602	241	389	376	762	127	1/2-14	324
24FKT1000	217004	49500	R2	865	159	184	848	236	602	241	384	381	880	127	3/4- 14	324
28FKT1000	217005	66900	R3	1129	171	203	866	254	602	254	368	389	981	127	3/4- 14	324
32FKT1000	217006	93800	R3	1592	197	267	919	305	605	305	419	404	1130	127	3/4- 14	325
38FKT1200	217007	154000	R4	2091	229	279	1055	330	713	330	432	457	1270	152	3/4- 14	381
42FKT1200	217008	185000	R4	2685	241	298	1156	432	713	432	508	500	1378	152	3/4- 14	384
46FKT1200	217009	215000	R4	2975	254	318	1158	432	713	432	516	528	1549	152	3/4- 14	387
52FKT1200	217010	275000	R4	3953	273	356	1184	432	738	432	495	505	1721	178	1-11 1/2	400
51FKT1600	217011	364000	R4	5243	305	394	1463	508	941	508	686	584	1721	178	1-11 1/2	508
60FKT1600	217012	493000	R4	8017	337	508	1579	610	954	610	706	660	1975	178	1 1/4 11 1/2	518
66FKT1600		633000	R4	10414	381	559	2083	5	940	762	610	559	2096	229	1 1/4 11 1/2	559
SI	N-m @ 5.2 bar			kg ³	Dimensiones en milímetros											

* Los datos presentados en los catálogos son indicativos y sujetos a modificación sin previo aviso.



FKT - Aplicación de Freno

Datos Técnicos

Serie Angosta 11,5 al 42

INGLES	lb	lb	lb-ft ²	lb	lb-ft ²
11,5FKT500	96	46	9	35	2
14FKT500	128	66	19	65	4
16FKT600	151	94	35	62	4
20FKT600	179	139	78	95	9
24FKT650	246	178	148	124	19
28FKT650	280	231	269	240	59
33FKT650	392	312	486	347	93
37FKT650	433	340	691	398	159
42FKT650	485	424	110	545	243
TAMAÑO	Peso	Peso	Wk ²	Peso	Wk ²
	Llanta	Campana		Cubo Porta Campana	
	Peso	Peso	J	Peso	J
11,5FKT500	43	21	0.38	16	0.08
14FKT500	58	30	0.80	29	0.17
16FKT600	68	43	1.47	28	0.17
20FKT600	81	63	3.28	43	0.38
24FKT650	111	81	6.23	56	0.80
28FKT650	127	105	11.32	109	2.48
33FKT650	178	141	20.46	157	3.91
37FKT650	196	154	29.09	180	6.69
42FKT650	220	192	46.31	247	10.23
SI	Kg	Kg	Kg-m ²	Kg	Kg-m ²

* Los datos presentados en los catálogos son indicativos y sujetos a modificación sin previo aviso.

TAMAÑO	N° de Parte		
	Llanta ①	Campana	Cubo Porta Campana
11,5FKT500	101002	216030	216330
14FKT500	101050	216040	216340
16FKT600	101102	216050	216350
20FKT600	101152	216060	216360
24FKT650	101202	216070	216370
28FKT650	101252	216080	216380
33FKT650	101300	216090	216390
37FKT650	101350	216100	216400
42FKT650	101400	216110	216410

NOTAS:

- 1- Solicitar por n° de parte. Con solicitud indicar n° de entradas de aire y tipo de conexión.
- 2- El torque indicado es dinámico, el torque estático es aproximadamente 25 % mayor. El torque en cada aplicación depende de la presión de aire y la velocidad.
- 3- Peso referido a mínimo Ø de eje.
- 4- Tolerancia por tamaño
 11,5 al 20 + 0,000/-0,005 pulg.
 (+0,00/-0,13 mm.)
 24 al 28 + 0,000/-0,008 pulg.
 (+0,00/-0,20 mm.)
 32 al 42 -0,000/-0,010 pulg.
 (+0,00/-0,25 mm.)

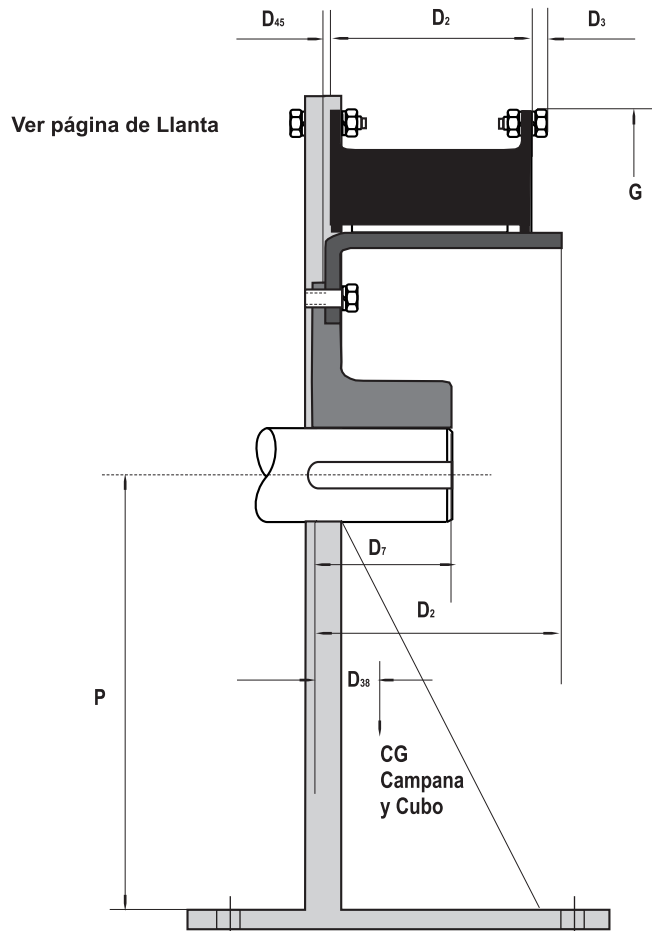

INGLES		lb.pulg @ 75 psi	lb	Dimensiones en pulgadas							
11.5FKT500	215201	27000	177	2.50	4.13	7.25	6.13	5.00	2.9	0.94	19.625
14FKT500	215202	39200	259	2.75	5.00	7.38	6.13	5.75	3.1	1.07	23.500
16FKT600	215203	65000	307	3.25	5.00	8.50	7.38	5.75	3.3	0.94	25.500
20FKT600	215204	93000	413	3.75	5.50	8.63	7.38	6.50	3.2	1.06	29.500
24FKT650	215205	135000	548	4.25	6.00	9.13	7.69	6.50	3.2	1.16	34.000
28FKT650	215206	182000	751	4.75	8.00	9.13	7.69	8.00	3.2	1.16	38.000
33FKT650	215207	255000	1051	5.25	9.50	9.13	7.69	9.00	3.5	1.16	44.625
37FKT650	215208	320000	1171	5.50	9.50	9.13	7.69	9.00	3.2	1.16	48.625
42FKT650	215209	380000	1454	6.00	10.50	9.13	7.69	10.00	3.4	1.16	53.625
Tamaño	N° de Parte ①	M. Torque Nomin. ②	Peso Total ③	min	max	D	D ₂	D ₇	D ₃₈	D ₄₅	G
				Rango de eje							
				min	max						
11.5FKT500	215201	3050	80	64	105	184	156	127	74	24	498.5
14FKT500	215202	4430	117	70	127	187	156	146	79	27	596.9
16FKT600	215203	7346	139	83	127	216	187	146	84	24	647.7
20FKT600	215204	10511	187	95	140	219	187	165	81	27	749.3
24FKT650	215205	15258	248	108	152	232	195	165	81	29	863.6
28FKT650	215206	20570	340	121	203	232	195	203	81	29	965.2
33FKT650	215207	28821	476	133	241	232	195	229	89	29	113.5
37FKT650	215208	36168	531	140	241	232	195	229	81	29	1235.1
42FKT650	215209	42949	659	152	267	232	195	254	86	29	1362.1
SI		N-m @ 5.2 bar	Kg	Dimensiones en milímetros							

* Los datos presentados en los catálogos son indicativos y sujetos a modificación sin previo aviso.



Serie Ancha 14 al 66

INGLES	lb	lb	lb-ft ²	lb	lb-ft ²
14FKT1000	213	122	35	70	5
16FKT1000	240	98	38	106	10
20FKT1000	282	169	112	173	23
24FKT1000	378	225	192	243	47
28FKT1000	431	295	350	332	88
32FKT1000	624	371	559	450	133
38FKT1200	684	552	1214	600	253
42FKT1200	895	582	1567	780	430
46FKT1200	980	729	2357	950	690
52FKT1200	1192	852	3552	1212	1136
51FKT1600	1934	890	4145	1961	2167
60FKT1600	2450	1640	8810	2604	3270
66FKT1600	2630	1905	19360	4940	6760
TAMAÑO	Wk ²	Peso	Wk ²	Peso	Wk ²
	Llanta	Campana		Cubo Campana	
	J	Peso	J	Peso	J
14FKT1000	96	55	1.47	32	0.21
16FKT1000	109	44	1.60	48	0.42
20FKT1000	128	77	4.71	78	0.97
24FKT1000	171	102	8.08	110	1.97
28FKT1000	195	134	14.73	150	3.70
32FKT1000	283	168	23.53	204	5.59
38FKT1200	310	250	51.10	272	10.65
42FKT1200	406	264	65.97	353	18.10
46FKT1200	444	330	99.23	430	29.04
52FKT1200	541	386	149.5	549	47.91
51FKT1600	877	403	174.5	889	91.23
60FKT1600	1111	744	370.9	1181	137.6
66FKT1600	1193	864	815.0	2240	284.5
SI	Kg	Kg	Kg-m ²	Kg	Kg-m ²

* Los datos presentados en los catálogos son indicativos y sujetos a modificación sin previo aviso.

TAMAÑO	N° de Parte		
	Llanta ①	Campana	Cubo Porta Campana
14FKT1000	102030	216120	216420
16FKT1000	102000	216130	216430
20FKT1000	102050	216140	216440
24FKT1000	102100	216150	216450
28FKT1000	102150	216160	216460
32FKT1000	102200	216170	216470
38FKT1200	102250	216180	216480
42FKT1200	102300	216190	216490
48FKT1200	102350	216200	216500
52FKT1200	102400	216210	216510
51FKT1600	102450	216220	216520
60FKT1600	102500	216230	216530
66FKT1600	102550	216240	216540

NOTAS:

- Solicitar por n° de parte.
Con solicitud indicar n° de entradas de aire y tipo de conexión.
- El torque indicado es dinámico, el torque estático es aproximadamente 25 % mayor.
El torque en cada aplicación depende de la presión de aire y la velocidad.
- Peso referido a mínimo Ø de eje.
- Tolerancia por tamaño
14 al 20 + 0,000/-0,005 pulg. (+0,00/-0,13 mm.)
24 al 28 + 0,000/-0,008 pulg. (+0,00/-0,20 mm.)
32 al 60 -0,000/-0,010 pulg. (+0,00/-0,25 mm.)
66 +0,000/-0,005 pulg. (+0,00/-0,13 mm.)

Ver página de Lanta

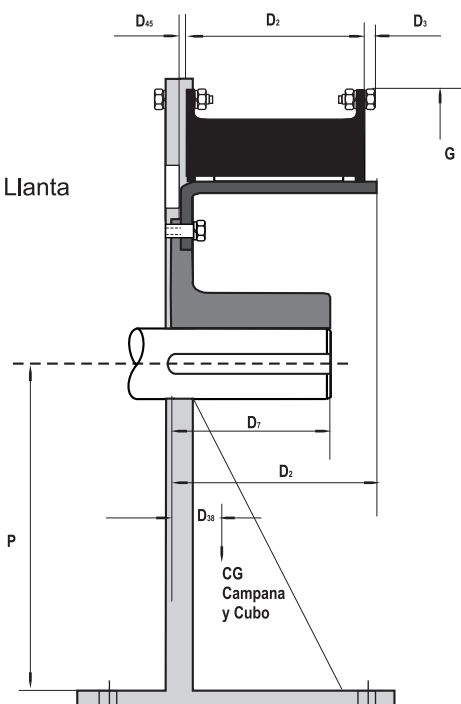

INGLES		lb.pulg @ 75 psi	lb	Dimensiones en pulgadas							
14FKT1000	217201	85000	405	3.63	5.00	12.38	11.56	7.00	5.0	0.75	23.500
16FKT1000	217202	114000	444	3.88	6.00	12.38	11.56	5.50	3.9	0.75	25.500
20FKT1000	217203	161000	624	4.50	6.25	12.38	11.56	7.00	4.3	0.75	29.500
24FKT1000	217204	219000	846	5.00	8.00	12.63	11.56	7.50	4.4	1.00	34.000
28FKT1000	217205	296000	1058	5.50	8.50	12.63	11.56	8.00	4.4	1.00	38.000
32FKT1000	217206	415000	1445	6.00	9.00	12.63	11.63	9.50	4.6	1.00	43.875
38FKT1200	217207	680000	1836	7.25	8.25	14.75	13.75	10.00	5.1	1.00	49.375
42FKT1200	217208	819000	2257	7.50	10.00	14.75	13.75	11.00	5.0	1.00	53.625
46FKT1200	217209	950000	2659	8.00	10.00	15.00	13.75	11.00	5.0	1.25	60.250
52FKT1200	217210	1215000	3256	8.75	11.00	15.25	14.25	12.50	5.1	1.25	67.000
51FKT1600	217211	1610000	4785	9.50	12.50	19.50	18.25	15.00	6.7	1.25	67.000
60FKT1600	217212	2183000	6694	10.50	18.00	19.63	18.50	16.00	6.9	1.50	77.000
66FKT1600	217213	2800000	9475	11.25	18.50	20.38	18.50	20.00	8.7	2.00	82.123
Tamaño	N° de Parte ¹	M. Torque Nomin. ²	Peso Total ³	Rango de eje		D	D ₂	D ₇	D ₃₈	D ₄₅	G ⁴
				mín	máx						
				mín	máx						
14FKT1000	217201	9610	183	92	127	314	2947	178	127	19	596.9
16FKT1000	217202	12884	201	99	152	314	294	140	99	19	647.7
20FKT1000	217203	18197	283	114	159	314	294	178	109	19	749.3
24FKT1000	217204	24752	383	127	203	321	294	191	112	25	863.6
28FKT1000	217205	33455	479	140	216	321	294	203	112	25	965.2
32FKT1000	217206	46905	655	152	229	321	295	241	117	25	1114.4
38FKT1200	217207	76857	832	184	235	375	349	254	130	25	1254.1
42FKT1200	217208	92567	1023	191	254	375	349	279	127	25	1362.1
46FKT1200	217209	10737	1206	203	254	381	349	279	127	32	1530.4
52FKT1200	217210	137325	1076	222	279	387	362	318	130	32	1701.8
51FKT1600	217211	181970	2170	241	318	495	464	381	170	32	1701.8
60FKT1600	217212	246733	3036	267	457	499	470	406	175	38	1955.8
66FKT1600	217213	316470	4297	286	470	518	470	508	221	51	2085.9
SI		N-m @ 5.2 bar	Kg	Dimensiones en milímetros							

* Los datos presentados en los catálogos son indicativos y sujetos a modificación sin previo aviso.



FKT - Componentes de Montaje Datos Técnicos y Dimensionales

Porta Llanta - Serie Angosta Simple

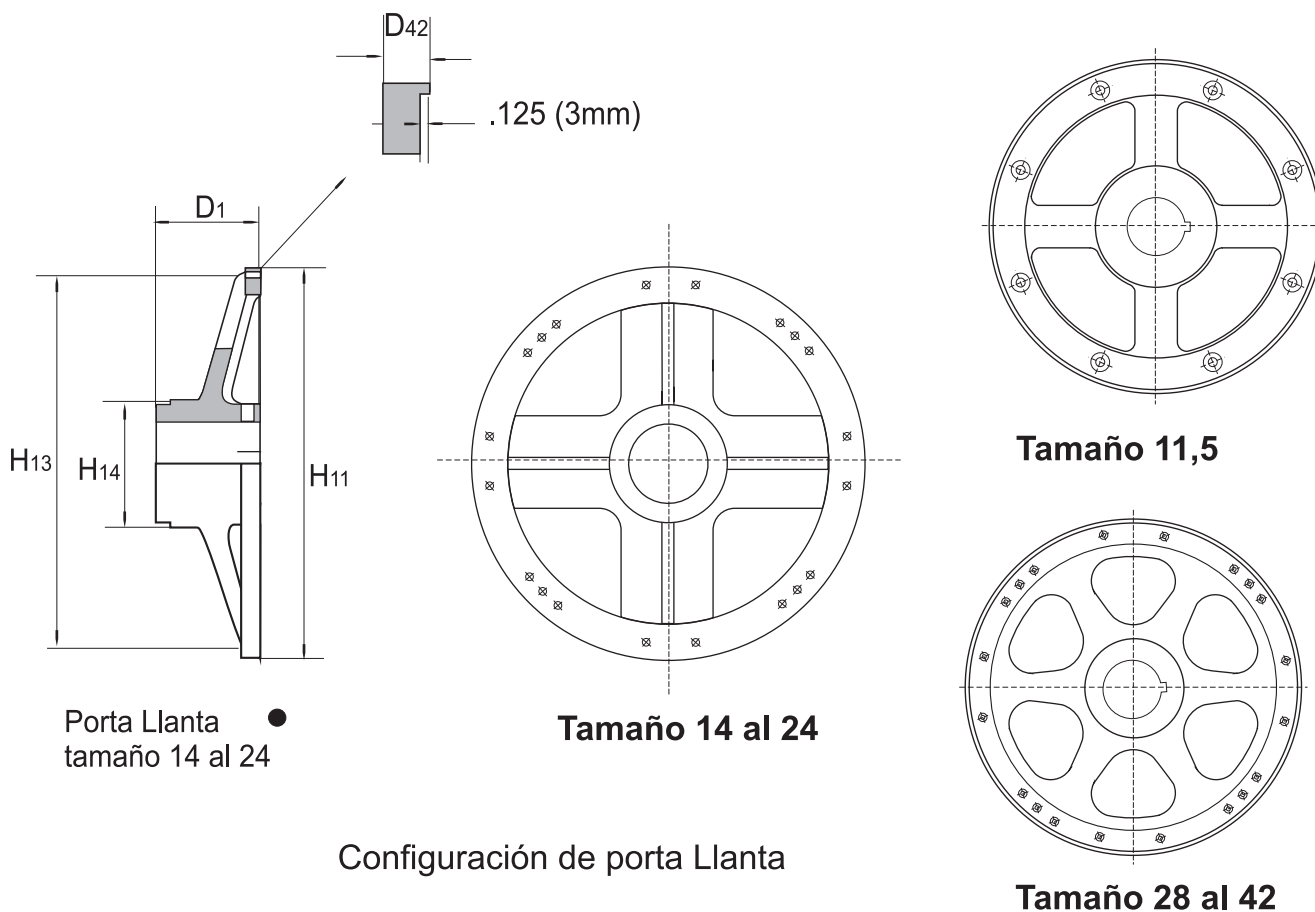

Porta Llanta tamaño 14 al 24

Tamaño 14 al 24

Tamaño 11,5

Tamaño 28 al 42

Configuración de porta Llanta

INGLES		lb	lb-ft ²	Dimensiones en pulgadas				
1.5FKT500	216630	70	19	4.34	0.59	20.00	N/A	6.00
14FKT500	216640	102	35	5.50	1.06	24.00	21.25	8.00
16FKT600	216650	139	50	5.50	1.06	26.00	23.25	8.00
20FKT600	216660	224	122	6.00	1.06	30.00	27.00	8.50
24FKT650	216670	260	174	6.50	1.06	34.63	31.00	9.00
28FKT650	216680	514	534	8.00	1.13	38.63	35.25	11.50
33FKT650	216690	716	811	9.00	1.13	45.25	41.00	13.50
37FKT650	216700	940	1404	10.00	1.25	49.25	45.50	13.50
42FKT650	216710	1284	2106	11.00	1.31	54.25	50.48	16.50

Tamaño	N° de Parte	Peso Total	Wk ²	D ₁	D ₄₂	H ₁₁	H ₁₃	H ₁₄
			J					
1.5FKT500	216630	32	0.80	110	15	508	N/A	152
14FKT500	216640	46	1.47	140	27	610	540	203
16FKT600	216650	63	2.11	140	27	660	591	203
20FKT600	216660	101	5.14	152	27	762	686	216
24FKT650	216670	118	7.33	165	27	880	787	229
28FKT650	216680	233	22.48	203	29	981	895	292
33FKT650	216690	324	34.14	229	29	1149	1041	343
37FKT650	216700	426	59.11	254	32	1251	1156	343
42FKT650	216710	582	88.66	279	33	1378	1282	419

SI	kg	Km ²	Dimensiones en milímetros				
----	----	-----------------	---------------------------	--	--	--	--

NOTAS:

- 1- Para otros tamaños, ver página de configuración y conexiones de aire de porta llanta en este catálogo.
- 2- N° de parte por doble pasaje de aire.
N° de parte por simple pasaje de aire 216633.
- 3- Peso referido a mínimo Ø de eje.

* Los datos presentados en los catálogos son indicativos y sujetos a modificación sin previo aviso.

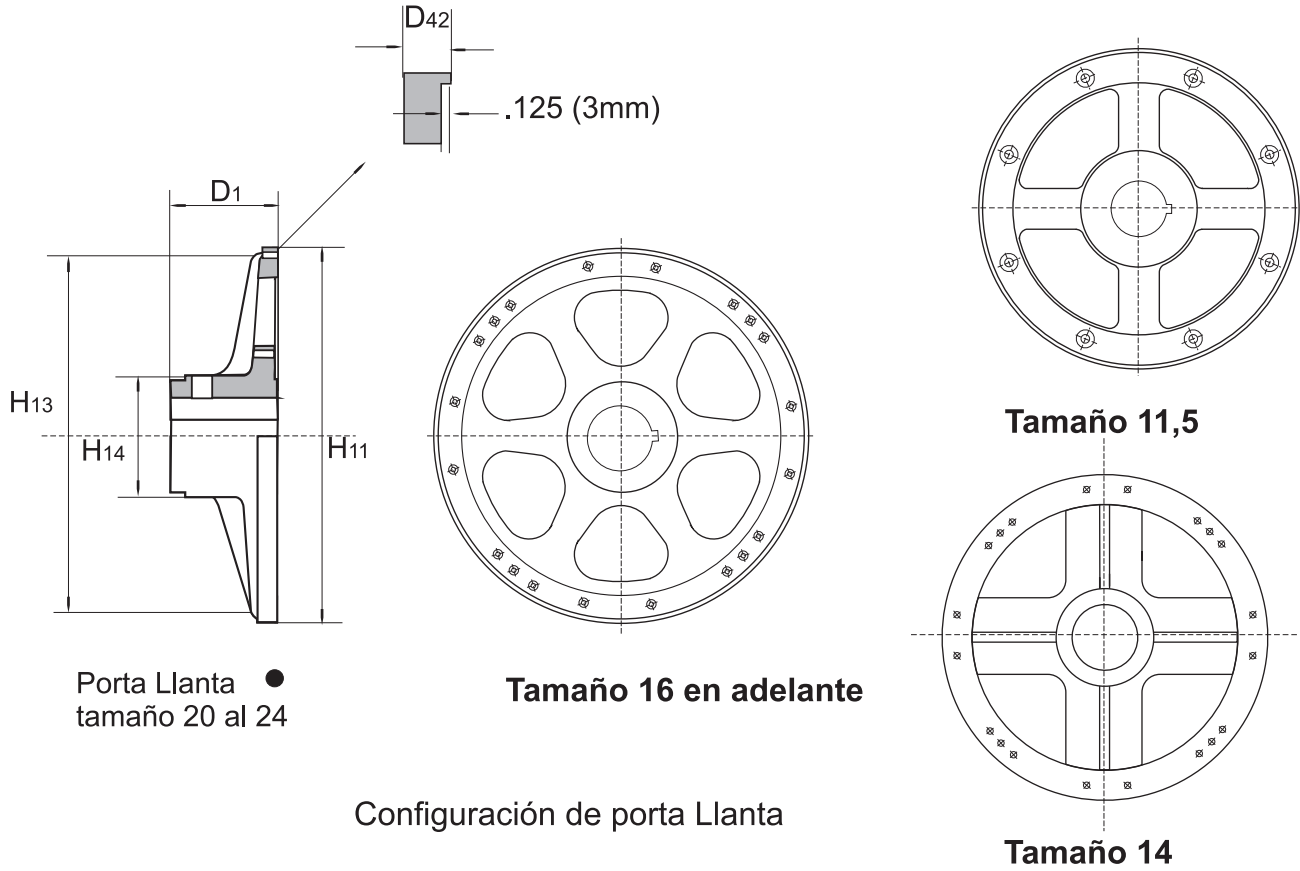

INGLES		lb	lb - ft ²	Dimensiones en pulgadas					
11.5FKT500	216631	² 71	19	4.84	0.62	20.00	N/A	7.50	
14FKT500	216641	102	35	5.50	1.06	24.00	21.25	8.00	
16FKT600	216651	236	111	5.50	1.50	26.00	23.00	10.00	
20FKT600	216661	295	167	7.00	1.13	30.00	27.00	10.00	
24FKT650	216671	408	285	7.75	1.13	34.63	31.50	12.00	
28FKT650	216681	554	474	8.00	1.13	38.63	35.25	14.00	
33FKT650	216691	802	965	9.00	1.13	45.25	41.00	15.00	
37FKT650	216701	981	1356	10.00	1.25	49.25	45.50	15.50	
42FKT650	216711	1116	1868	11.00	1.31	54.25	50.50	16.50	
Tamaño	N° de Parte	Peso Total	Wk ² J	D ₁	D ₄₂	H ₁₁	H ₁₃	H ₁₄	
11.5FKT500	216631	32.20	0.80	123	15	508	N/A	152	
14FKT500	216641	46.26	1.47	140	27	610	540	203	
16FKT600	216651	107.05	4.67	140	38	660	591	203	
20FKT600	216661	133.81	7.03	177	28	762	686	216	
24FKT650	216671	185.06	11.99	197	28	880	787	229	
28FKT650	216681	251.29	19.95	203	28	981	895	292	
33FKT650	216691	363.78	40.62	229	28	1149	1041	343	
37FKT650	216701	444.98	57.08	254	31	1251	1156	343	
42FKT650	216711	506.21	78.64	279	33	1378	1282	419	
SI	kg	Km ²	Dimensiones en milímetros						

NOTAS:

1- Para otros tamaños, ver página de configuración y conexiones de aire de porta llanta en este catálogo.

2- Peso referido a mínimo Ø de eje.

* Los datos presentados en los catálogos son indicativos y sujetos a modificación sin previo aviso.



FKT - Componentes de Montaje Datos Técnicos y Dimensionales

Porta Llanta - Serie Ancha Simple

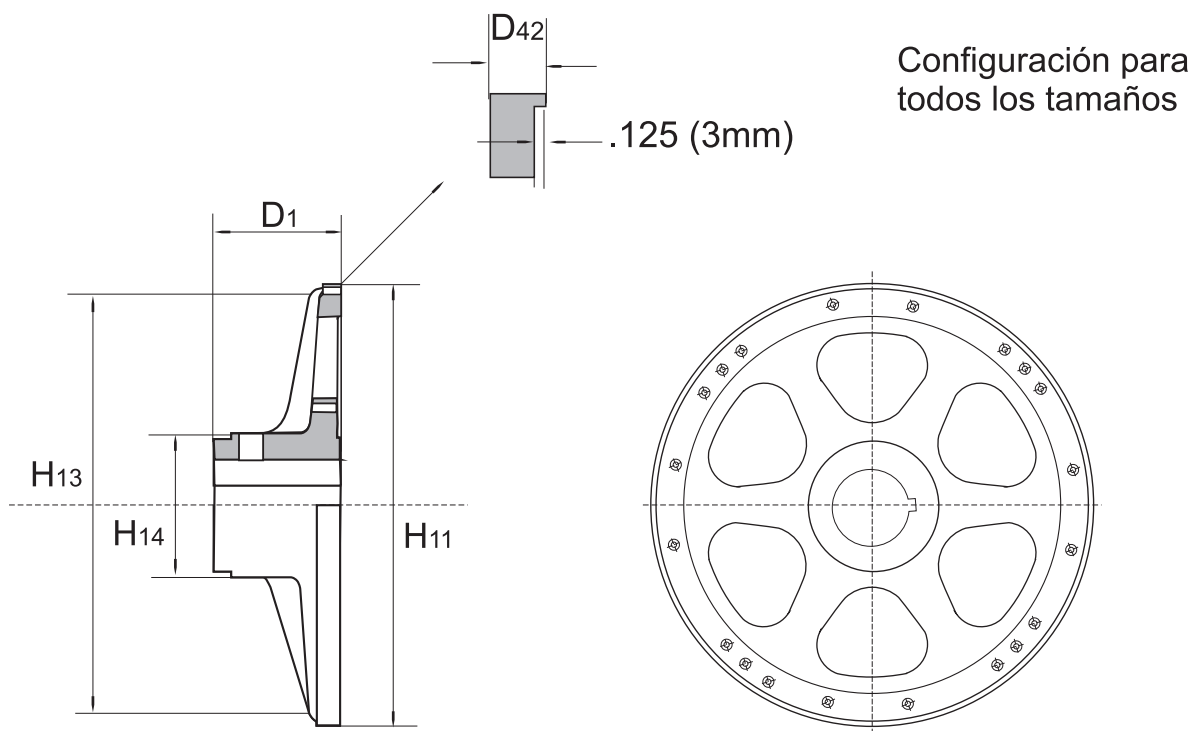

INGLES	lb	lb - ft ²	Dimensiones en pulgadas					
14FKT1000	216720	² 205	79	5.50	1.13	24.00	20.00	8.00
16FKT1000	216730	236	11	5.50	1.50	26.00	23.00	10.00
20FKT1000	216740	295	167	7.00	1.13	30.00	27.00	10.00
24FKT1000	216750	408	285	7.75	1.13	34.63	31.50	12.00
28FKT1000	216760	554	474	8.00	1.13	38.63	35.25	14.00
32FKT1000	216770	727	781	9.00	1.13	44.50	41.00	15.00
38FKT1000	216780	1002	1502	10.00	1.25	50.00	45.50	15.50
42FKT1000	216790	1116	1868	11.00	1.31	54.25	50.50	16.50
46FKT1000	216800	1504	2968	11.00	1.50	61.00	56.50	17.00
52FKT1200	216810	2579	5087	12.50	1.69	67.75	63.25	23.00
51FKT1600	216820	2621	6706	15.00	1.69	67.75	63.25	20.00
60FKT1600	216830	4096	13346	16.00	1.88	77.75	63.25	26.00

Tamaño	N° de Parte	Peso Total	$\frac{Wk^2}{J}$	D ₁	D ₄₂	H ₁₁	H ₁₃	H ₁₄
			J					
14FKT1000	216720	93	3.32	140	29	600	533	203
16FKT1000	216730	107	4.67	140	38	660	584	254
20FKT1000	216740	134	7.03	178	29	762	686	254
24FKT1000	216750	185	12.00	197	29	880	800	305
28FKT1000	216760	251	19.96	203	29	981	895	356
32FKT1000	216770	329	32.88	229	29	1130	1041	381
38FKT1000	216780	454	63.23	254	32	1270	1156	394
42FKT1000	216790	506	78.64	279	33	1378	1283	419
46FKT1000	216800	682	124.9	279	38	1549	1435	432
52FKT1200	216810	1169	214.1	318	43	1721	1607	584
51FKT1600	216820	1188	282.3	381	43	1721	1607	508
60FKT1600	216830	1858	561.8	406	48	1975	1829	660
SI	kg	Km ²	Dimensiones en milímetros					

NOTAS:

1- Para otros tamaños, ver página de configuración y conexiones de aire de porta llanta en este catálogo.

2- Peso referido a mínimo Ø de eje.

* Los datos presentados en los catálogos son indicativos y sujetos a modificación sin previo aviso.

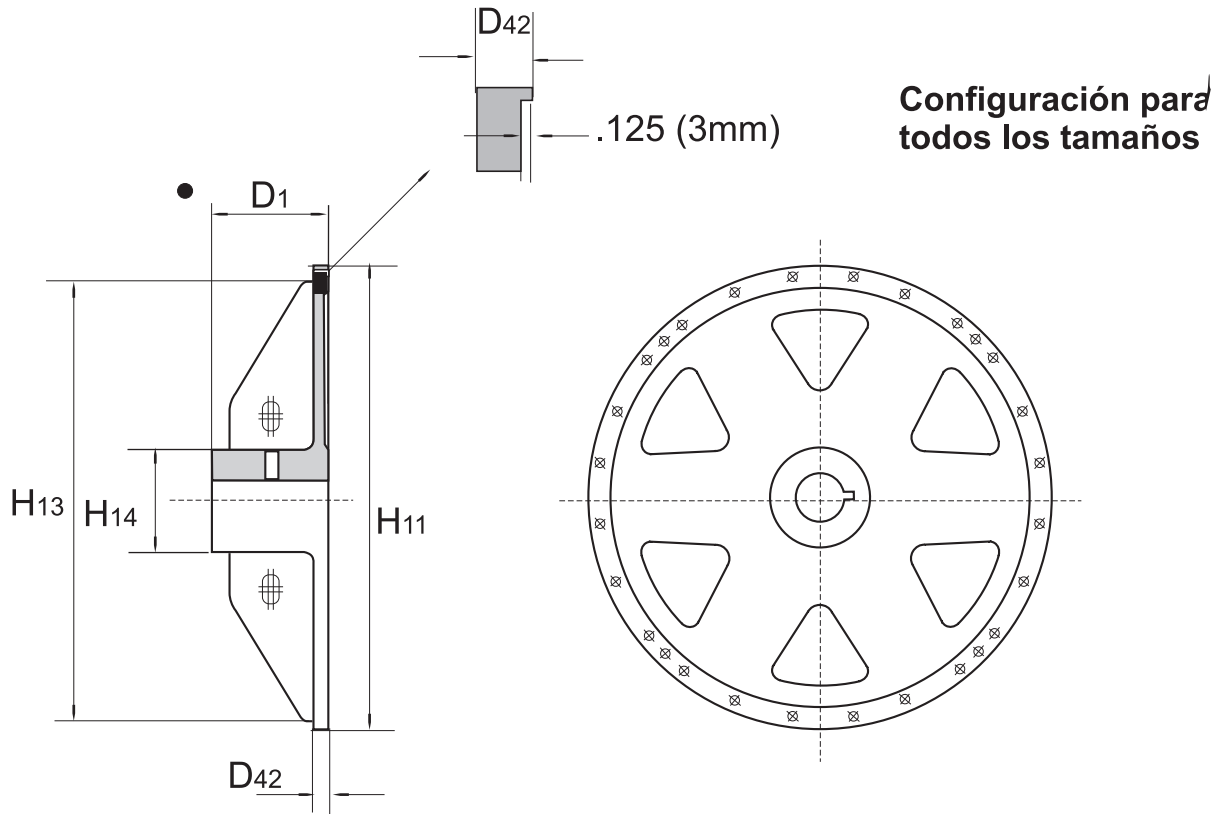

INGLES		lb	lb - ft ²	Dimensiones en pulgadas				
16FKT1000	216731	² 264	113	8.00	1.50	26.00	23.00	10.00
20FKT1000	216741	333	197	9.50	1.13	30.00	27.00	11.00
24FKT1000	216751	442	312	9.31	1.13	34.63	31.50	12.50
28FKT1000	216761	680	597	10.00	1.13	38.63	35.25	14.00
32FKT1000	216771	967	932	12.00	1.13	44.50	41.00	16.75
38FKT1200	216781	1350	1625	13.00	1.25	50.00	45.50	18.50
42FKT1200	216791	1763	2445	17.00	1.31	54.25	50.50	19.00
46FKT1200	216801	1855	3577	17.00	1.44	61.00	56.50	20.00
52FKT1200	216811	2854	5277	17.00	1.69	67.75	63.25	23.00
51FKT1600	216821	3639	7611	20.00	1.69	67.75	63.25	25.00
60FKT1600	216831	5402	14489	24.00	1.88	77.75	72.00	30.00
Tamaño	N° de Parte	Peso Total	Wk ²	D ₁	D ₄₂	H ₁₁	H ₁₃	H ₁₄
			J					
16FKT1000	216731	120	4.75	203	38	660	584	254
20FKT1000	216741	151	8.29	241	29	762	686	279
24FKT1000	216751	200	13.13	236	29	880	800	318
28FKT1000	216761	308	25.13	254	29	981	895	356
32FKT1000	216771	438	39.23	305	29	1130	1041	425
38FKT1200	216781	612	68.41	330	32	1270	1156	460
42FKT1200	216791	799	102.9	432	33	1378	1283	483
46FKT1200	216801	841	150.5	432	37	1549	1435	508
52FKT1200	216811	1294	222.1	432	43	1721	1607	584
51FKT1600	216821	1650	320.4	508	43	1721	1607	635
60FKT1600	216831	2450	609.9	610	48	1975	1829	762
SI		kg	Kg.m ²	Dimensiones en milímetros				

NOTAS:

- 1- Para otros tamaños, ver página de configuración y conexiones de aire de porta llanta en este catálogo.
- 2- Peso referido a mínimo Ø de eje.

* Los datos presentados en los catálogos son indicativos y sujetos a modificación sin previo aviso.



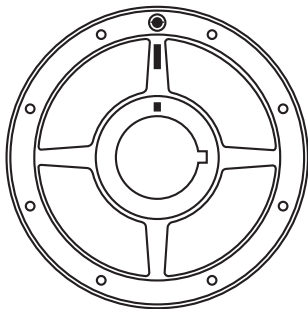

Una Conexión

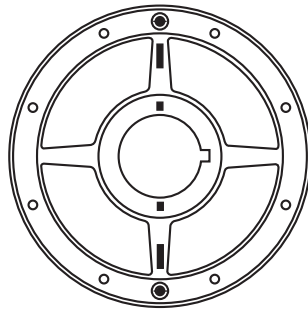

Dos Conexiones

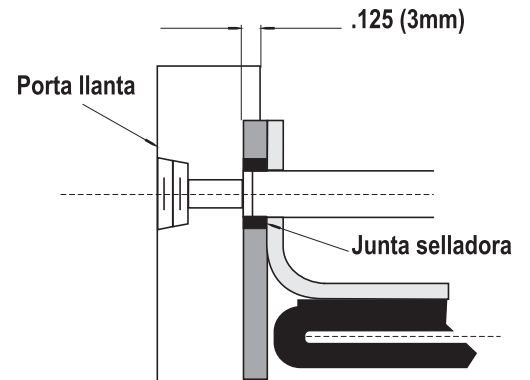

Disposición de conexión de aire externa para todos los tamaños, configuración simple o doble y serie angosta y ancha de llanta FKT.

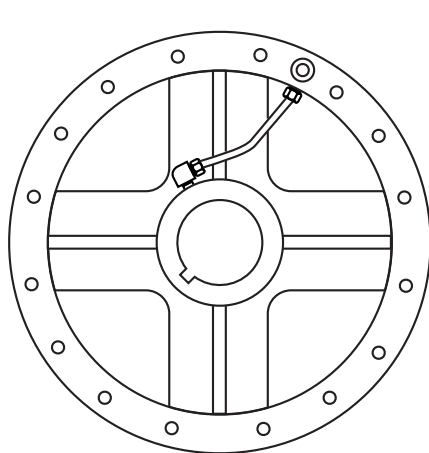

Una Conexión



Dos Conexiones

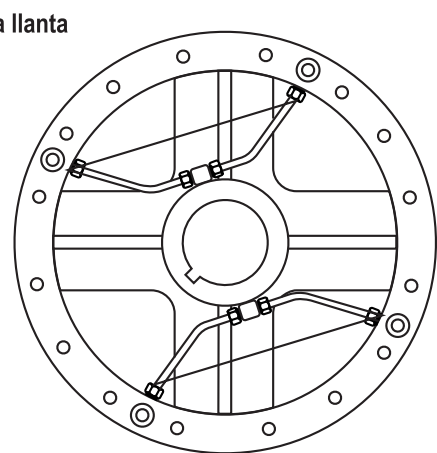

Cuatro Conexiones

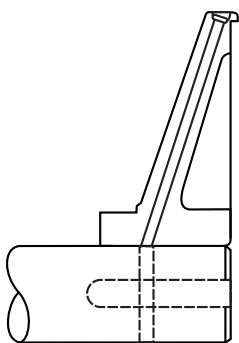

Simple y Dual 11,5

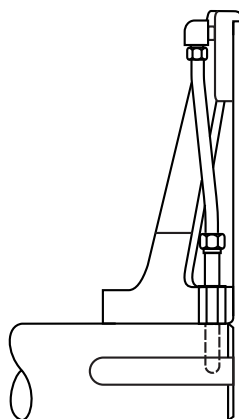

Simple Angosta 14 al 24
Dual Angosta 14

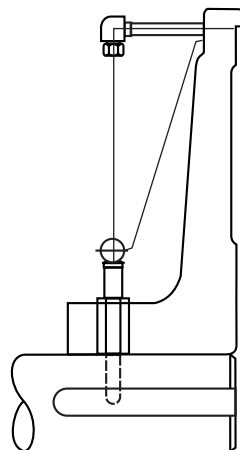

Dual Angosta 20 al 24
Simple y Dual Ancha 20 al 24

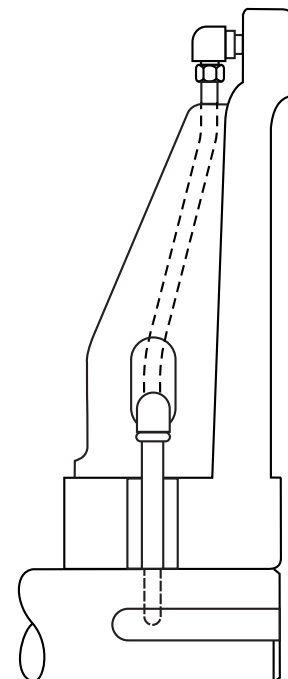

Dual Angosta 16
Simple y Dual Angosta 28 al 42
Simple Ancha 14-FKT
Simple y Dual Ancha 16-FKT 28 al 60

FKT - Componentes de Montaje
 Datos Técnicos y Dimensionales
 Adaptador Ventilado - Serie Angosta

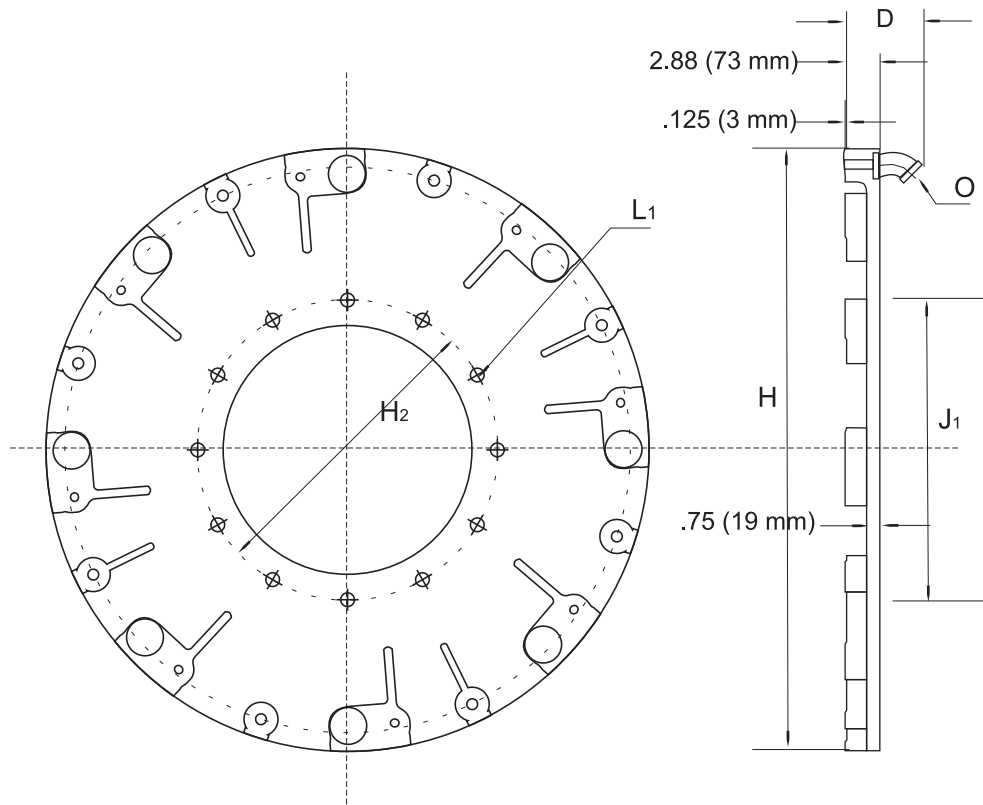

INGLES			lb	lb-ft ²	lb	lb-ft ²	Dimensiones en pulgadas						
11,5FKT500	216901	216911	28	13	73	35	3.94	20.38	8.250	9.25	6	0.53	1/4-8
14FKT500	216902	216912	38	16	103	70	3.94	24.63	10.750	12.00	6	0.78	3/8-18
16FKT600	216903	216913	48	40	130	108	4.38	26.63	12.125	13.50	8	0.78	3/8-18
20FKT600	216904	216914	56	63	146	167	4.38	30.63	16.750	18.50	10	0.78	3/8-18
24FKT650	216905	216915	74	110	194	297	4.38	35.13	19.500	21.50	14	0.78	3/8-18
28FKT650	216906	216916	81	157	219	424	4.38	39.13	23.00	25.00	18	0.78	3/8-18
33FKT650	216907	216917	96	255	259	686	4.44	45.88	29.000	31.00	20	0.78	1/2-14
37FKT650	216908	216918	121	381	321	1026	4.44	49.88	32.500	34.50	16	0.78	1/2-14
42FKT650	216909	216919	143	575	378	1550	4.44	54.88	37.500	35.50	10	1.03	1/2-14
Tamaño	N° de Parte Llanta Simple	N° de Parte Llanta Dual	Peso		Wk ²		D	H	J ₁	H ₂	N°		O ³
			Adaptador Simple ¹		Adaptador Dual ¹						L ₁		
			Peso	J	Peso	J					N°	Tamaño	
11,5FKT500	216901	216911	13	0.55	33	1.47	100	518	210	235	6	13	1/4-8
14FKT500	216902	216912	17	0.67	47	2.94	100	626	273	305	6	20	3/8-18
16FKT600	216903	216913	22	1.68	59	4.54	111	676	308	343	8	20	3/8-18
20FKT600	216904	216914	25	2.65	66	7.03	111	778	425	470	10	20	3/8-18
24FKT650	216905	216915	34	4.63	87	12.50	111	892	495	540	14	20	3/8-18
28FKT650	216906	216916	37	6.61	99	17.85	111	994	584	635	18	20	3/8-18
33FKT650	216907	216917	43	10.73	117	28.88	113	1165	737	787	20	20	1/2-14
37FKT650	216908	216918	55	16.04	145	43.19	113	1267	826	876	16	20	1/2-14
42FKT650	216909	216919	65	24.20	171	65.25	113	1394	953	1003	10	26	1/2-14
SI			Kg	Kg.m ²	Kg ³	Kg.m ²	Dimensiones en milímetros						

NOTAS: 1- Adaptación simple fabricada en aleación de aluminio, adaptación dual fabricada en fundición de acero. 2- Tolerancia + 0.005/-0.000 pulg. (+ 0,13/-0,00 mm.) 3- Rosca NPT.

Los datos presentados en los catálogos son indicativos y sujetos a modificación sin previo aviso.



FKT - Componentes de Montaje Datos Técnicos y Dimensionales

Campana Interior - Serie Angosta

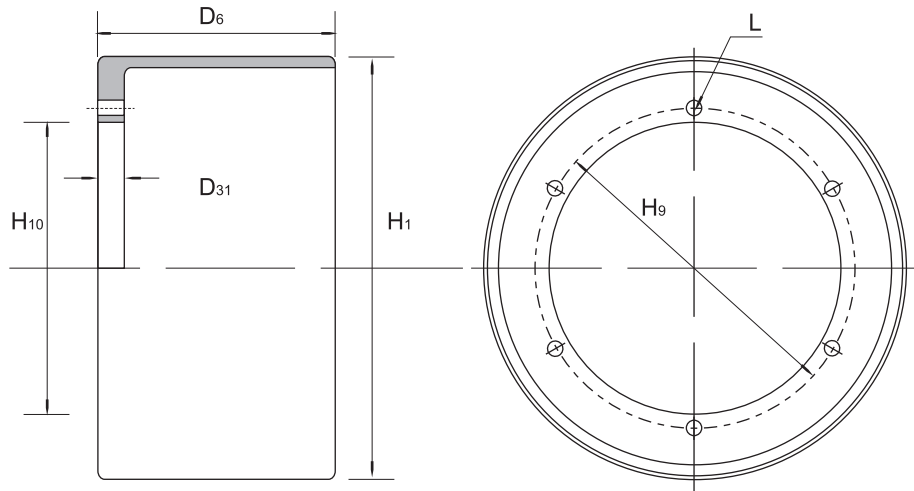

INGLES	Dimensiones en pulgadas								lb	lb-ft ²	Pulgadas	lb	lb-ft ²
	D ₃₁	H ₁₀	H ₉	H ₁	N°	Pasante	Roscado	D ₆					
11,5FKT500	0.75	11.5	7.250	6.250	6	0.53	1/2-13	6.50	46	9	13.13	83	16
14FKT500	0.75	14.0	9.250	8.250	12	0.53	1/2-13	6.50	66	19	13.13	139	40
16FKT600	0.75	16.0	9.625	8.250	8	0.78	3/4-10	7.75	94	35	15.63	175	66
20FKT600	1.00	20.0	12.000	10.500	12	0.78	3/4-10	7.75	139	78	15.63	234	138
24FKT650	1.00	24.0	16.000	14.625	12	0.78	3/4-10	8.25	178	148	16.38	293	258
28FKT650	1.00	28.0	20.000	18.500	16	0.78	3/4-10	8.25	231	269	16.38	348	472
33FKT650	1.00	33.0	21.500	19.500	14	0.78	3/4-10	8.25	312	486	16.44	507	827
37FKT650	1.00	37.0	27.000	25.000	18	0.78	3/4-10	8.25	340	691	16.44	553	1172
42FKT650	1.13	42.0	31.000	29.000	20	0.78	3/4-10	8.25	424	1100	16.44	662	1809
Tamaño	D ₃₁	H ₁	H ₉	H ₁₀	N°			Campana Simple			Campana Simple		
					Agujero			Campana Simple			Campana Simple		
					Pasante	Roscado		D ₆	Peso	Wk ²	D ₆	Peso	Wk ²
N°	Pasante	Roscado	D ₆	Peso	J	D ₆	Peso	J					
11,5FKT500	19	292	184.2	158.7	6	13	1/2-13	165	21	0.38	333	38	0.67
14FKT500	19	356	235.0	209.6	12	13	1/2-13	165	30	0.80	333	63	1.68
16FKT600	19	406	244.5	209.6	8	20	3/4-10	196	43	1.47	397	79	2.78
20FKT600	25	508	304.4	266.7	12	20	3/4-10	196	63	3.28	397	106	5.81
24FKT650	25	612	406.4	371.5	12	20	3/4-10	210	81	6.23	416	133	10.86
28FKT650	25	711	508.0	469.9	16	20	3/4-10	210	105	11.32	416	158	19.87
33FKT650	25	383	546.1	495.3	14	20	3/4-10	210	141	20.46	418	230	34.82
37FKT650	25	940	685.8	635.0	18	20	3/4-10	210	154	29.09	418	251	49.34
42FKT650	29	1067	787.4	736.6	20	20	3/4-10	210	192	46.31	418	300	76.16
SI	Dimensiones en milímetros								Kg	Kg.m ²	mm	Kg	Kg.m ²

TAMAÑO	N° de Parte Campana			
	Llanta Simple		Llanta Dual	
	Agujero Pasante	Agujero Roscado	Agujero Pasante	Agujero Roscado
11,5FKT500	216032	216030	216033	216031
14FKT500	216042	216040	216043	216041
16FKT600	216052	216050	216053	216051
20FKT600	216062	216060	216063	216061
24FKT650	216072	216070	216073	216071
28FKT650	216082	216080	216083	216081
33FKT650	216092	216090	216093	216091
37FKT650	216102	216100	216103	216101
42FKT650	216112	216110	216113	216111

NOTAS:

- 1- Tolerancia + 0.000/-0.010 pulg. (+ 0,00/-0,25 mm.)
- 2- Tolerancia + 0.003/-0.000 pulg. (+ 0,08/-0,00 mm.)
- 3- Rosca Americana NC

* Los datos presentados en los catálogos son indicativos y sujetos a modificación sin previo aviso.

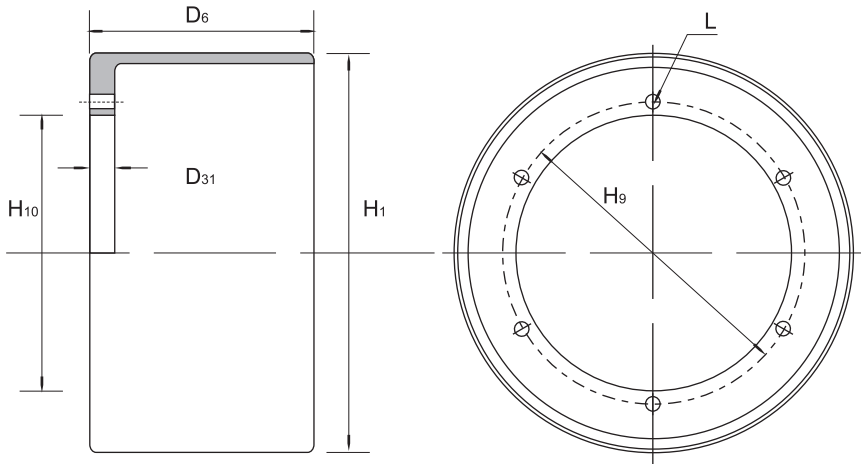

TAMAÑO	N° de parte Campana	
	Macho	Hembra
14FKT1000	216120	N/A
16FKT1000	216140	216141
20FKT1000	216150	216151
24FKT1000	216160	216161
28FKT1000	216170	216171
32FKT1000	216180	216181
38FKT1000	216190	216191
42FKT1200	216200	216201
46FKT1200	216210	216211
52FKT1200	216220	216221
51FKT1600	216230	216231
60FKT1600	216240	216241
66FKT1600	216250	216251

NOTAS:

1- Las campanas son suministradas sin rebaje.

2- El n° de parte no mostrado para campana 16 es 216130 y son 10 agujeros de 3/4 ANC.

3- Tolerancia +0.000/-0.010 pulg. (+ 0,00/-0,25 mm.)

4- Tolerancia por tamaño:
 14 al 51 + 0.003/-0.000 pulg. (+ 0,08/-0,00 mm.)
 60 al 66 + 0.005/-0.000 pulg. (+ 0,13/-0,00 mm.)

5- 16 Agujeros, disponible 14 a 180° no se utiliza.

6- 24 Agujeros, disponible 22 a 180° no se utiliza.

7- 32 Agujeros, disponible 30 a 180° no se utiliza.

8- 36 Agujeros, disponible 34 a 180° no se utiliza.

9- Se provee únicamente con agujeros roscados 1/2-13 ANC.

INGLES	Dimensiones en pulgadas							lb	lb-ft ²	Pulgadas	lb	lb-ft ²			
14FKT1000	11.50	14	9.250	8.250	12	9	0.88	122	35	N/A	N/A	N/A			
16FKT1000	11.50	16	11.500	10.000	25	5	0.78	1.00	98	38	0.88	90	37		
20FKT1000	11.50	20	15.500	13.500	5	5	0.78	1.00	169	112	0.88	164	109		
24FKT1000	11.50	24	16.000	14.625	5	5	0.78	1.00	225	192	0.88	215	186		
28FKT1000	11.50	28	20.000	18.500	5	5	0.78	1.00	295	350	0.88	282	338		
32FKT1000	11.50	32	21.000	19.000	6	6	0.78	1.00	371	559	0.88	352	537		
38FKT1200	13.63	38	27.000	25.000	7	7	0.78	1.00	552	1214	0.88	530	1173		
42FKT1200	13.63	42	31.000	29.000	8	8	0.78	1.13	582	1567	1.00	550	1510		
46FKT1200	13.63	46	34.500	32.500	7	7	1.06	1.25	729	2357	1.13	700	2276		
52FKT1200	13.85	52	40.000	38.000	6	6	1.06	1.25	852	3552	1.13	820	3425		
51FKT1600	18.13	51	40.000	38.000	6	6	1.06	1.25	890	4145	1.13	860	4035		
60FKT1600	17.75	60	46.000	42.000	24	156	1.75	1.75	1640	8810	1.63	1590	8575		
66FKT1600	18.25	66	48.000	44.000	8	156	1.75	1.75	1905	15070	1.50	1770	14340		
Tamaño	D ₆	H ₁	H ₉	H ₁₀	N° Tamaño		D ₃₁	Peso	Wk ²	Campana (macho)			Campana (hembra)		
					Agujero	L				D ₃₁	Peso	J	D ₃₁	Peso	J
N°	Tamaño	D ₃₁	Peso	J	D ₃₁	Peso	J	D ₃₁	Peso	J	D ₃₁	Peso	J		
14FKT1000	292	356	235.0	209.6	12	9	22	55	1.47	N/A	N/A	N/A	N/A		
16FKT1000	292	406	292.1	254.0	25	5	25	44	1.60	22	43	1.55	22	43	1.55
20FKT1000	292	508	381.0	342.9	5	5	25	77	4.71	22	74	4.58	22	74	4.58
24FKT1000	292	610	406.4	371.5	5	5	25	102	8.08	22	97	7.83	22	97	7.83
28FKT1000	292	711	508.0	469.9	5	5	25	134	14.73	22	128	14.23	22	128	14.23
32FKT1000	292	813	533.4	482.6	6	6	25	168	23.53	22	159	22.60	22	159	22.60
38FKT1200	346	965	685.8	635.0	7	7	25	250	51.10	22	240	49.38	22	240	49.38
42FKT1200	346	1067	787.4	736.6	8	8	29	264	65.97	22	249	63.57	22	249	63.57
46FKT1200	346	1168	876.3	825.5	7	7	26	320	99.23	29	317	95.82	29	317	95.82
52FKT1200	351	1321	1016.0	965.2	6	6	27	386	149.5	29	371	144.1	29	371	144.1
51FKT1600	461	1295	1016.0	965.2	6	6	27	403	174.5	29	390	169.8	29	390	169.8
60FKT1600	451	1524	1168.4	1066.8	24	40	44	743	370.9	41	721	361.0	41	721	361.0
66FKT1600	464	1676	1219.2	1117.6	8	40	44	864	634.44	38	802	603.7	38	802	603.7
SI	Dimensiones en milímetros							Kg	Kg.m ²	mm	Kg	Kg.m ²			

* Los datos presentados en los catálogos son indicativos y sujetos a modificación sin previo aviso.



FKT - Componentes de Montaje

Datos Técnicos y Dimensionales

Cubo Porta Campana - Serie Angosta

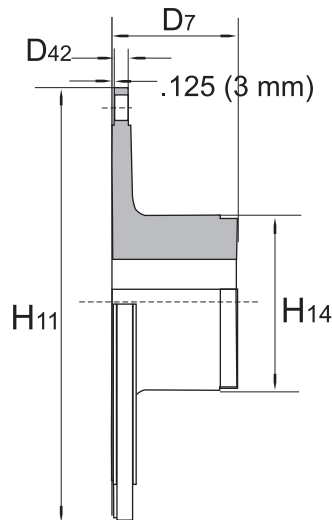

Agujero pasante o roscado

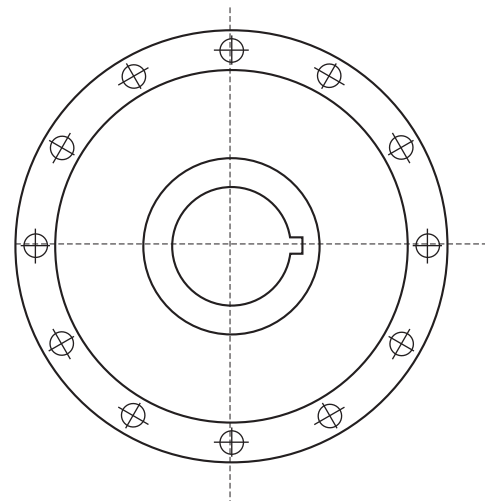

TAMAÑO	N° de Parte Campana			
	Llanta Simple		Llanta Dual	
	Agujero Pasante	Agujero Roscado	Agujero Pasante	Agujero Roscado
11,5FKT500	216630	216632	216631	216633
14FKT500	216640	216642	216641	216643
16FKT600	216650	216652	216651	216653
20FKT600	216660	216662	216661	216663
24FKT650	216670	216672	216671	216673
28FKT650	216680	216682	216681	216683
33FKT650	216690	216692	216691	216693
37FKT650	216700	216702	216701	216703
42FKT650	216710	216712	216711	216713

NOTAS:

1- Datos referidos a agujeros mínimos.

INGLES	Pulgadas	lb	lb-ft ²	Dimensiones en pulgadas			lb	lb-ft ²	Dimensiones en pulgadas		
11,5FKT500	8.25	35	2	5.00	0.63	6.0	43	2	7.00	0.63	6.0
14FKT500	10.25	65	4	5.75	0.75	7.5	60	4	5.75	0.75	7.5
16FKT600	11.13	62	4	5.75	0.63	7.5	82	6	6.50	0.75	8.0
20FKT600	13.50	95	9	6.50	0.75	8.5	124	13	7.00	0.75	10.0
24FKT650	17.50	124	19	5.60	0.75	9.0	215	42	7.50	1.00	12.0
28FKT650	21.50	240	59	8.00	0.75	11.5	292	85	8.00	1.00	13.0
32FKT650	23.00	347	93	9.00	0.75	13.5	395	123	9.50	1.00	14.5
38FKT650	28.50	398	159	9.00	0.75	13.5	528	240	10.00	1.00	15.5
42FKT650	32.50	545	246	10.00	0.75	15.0	647	413	11.00	1.00	16.5

Tamaño	H ₁₁	Para Llanta Simple					Para Llanta Dual				
		Peso	Wk ²	D ₇	D ₄₂	H ₁₄	Peso	Wk ²	D ₇	D ₄₂	H ₁₄
		g	J	D ₇	D ₄₂	H ₁₄	g	J	D ₇	D ₄₂	H ₁₄
11,5FKT500	209.5	16	0.08	127.0	16.0	152	19	0.08	178	16	152
14FKT500	260.3	29	0.17	146.0	19.0	191	27	0.17	146	19	191
16FKT600	288.7	28	0.17	146.0	19.0	191	27	0.25	165	19	203
20FKT600	342.9	43	0.38	165.1	21.6	216	56	0.55	178	19	254
24FKT650	444.5	56	0.80	142.2	22.8	229	97	1.76	191	25	305
28FKT650	546.1	109	2.48	203.2	29.2	292	132	3.57	203	25	330
32FKT650	584.2	157	3.91	228.6	34.3	343	179	5.17	241	25	368
38FKT650	723.9	180	6.68	228.6	34.3	343	239	10.08	254	25	394
42FKT650	825.5	247	10.21	254.0	38.1	381	293	17.35	279	25	419

* Los datos presentados en los catálogos son indicativos y sujetos a modificación sin previo aviso.

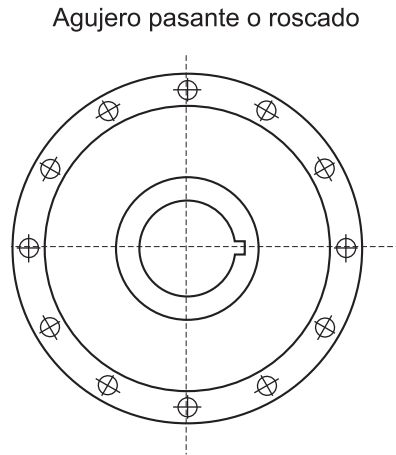
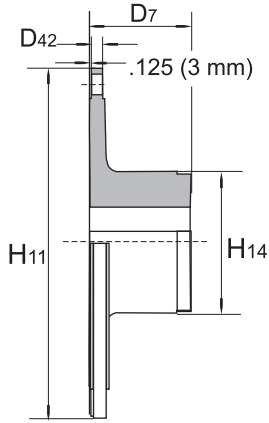

TAMAÑO	N° de Parte Campana			
	Llanta Simple		Llanta Dual	
	Agujero Pasante	Agujero Roscado	Agujero Pasante	Agujero Roscado
14FKT1000	216420			
16FKT1000	216430	216432	216431	216433
20FKT1000	216440	216442	216441	216443
24FKT1000	216450	216452	216451	216453
28FKT1000	216460	216462	216461	216463
32FKT1000	216470	216472	216471	216473
38FKT1200	216480	216482	216481	216483
42FKT1200	216490	216492	216491	216493
46FKT1200	216500	216502	216501	216503
52FKT1200	216510	216512	216511	216513
51FKT1600	216520		216521	
60FKT1600	216530		216531	
66FKT1600			216541	

NOTAS:

- 1- 0.25 (26 mm.) para tamaño 66.
- 2- Datos referidos a agujeros mínimos.

INGLES	Pulgadas		lb	lb-ft ²	Pulgadas		lb	lb-ft ²	Pulgadas	
14FKT1000	0.75	10.25	70	5	7.00	7.50				
16FKT1000	0.75	13.00	97	9	5.50	9.50	199	19	10.00	9.50
20FKT1000	0.75	16.50	150	21	7.00	10.00	203	32	9.50	11.00
24FKT1000	1.00	17.50	215	44	7.50	12.00	271	50	9.50	12.75
28FKT1000	1.00	21.50	297	82	8.00	13.00	370	99	10.00	14.00
32FKT1000	1.00	22.50	407	127	9.50	14.50	574	185	12.00	16.50
38FKT1200	1.00	28.50	521	236	10.00	15.50	806	368	13.00	18.50
42FKT1200	1.00	32.50	677	378	11.00	16.50	1233	653	17.00	20.00
46FKT1200	1.25	36.50	813	577	11.00	17.00	1316	856	17.00	20.00
52FKT1200	1.25	42.00	1125	1000	12.50	18.50	1803	1514	17.00	23.00
51FKT1600	1.25	42.00	1475	1150	15.00	20.00	2303	1993	20.00	25.00
60FKT1600	1.75	49.00	2526	3034	16.00	26.00	4143	4967	24.00	30.00
66FKT1600	2.00	51.50	4940	6760	20.00	34.00	6450	9140	30.00	34.00
Tamaño	D ₄₂	H ₁₁	Para Llanta Simple				Para Llanta Dual			
			Peso	Wk ²	D ₇	H ₁₄	Peso	Wk ²	D ₇	H ₁₄
			J	D ₇	H ₁₄	J	D ₇	H ₁₄		
14FKT1000	19	260	32	0.21	178	191				
16FKT1000	19	330	44	0.38	140	241	90	0.80	254	241
20FKT1000	19	419	68	0.88	178	254	92	1.34	241	279
24FKT1000	25	445	98	1.85	191	305	123	2.10	254	324
28FKT1000	25	546	135	3.45	203	330	168	4.16	305	356
32FKT1000	25	572	185	5.34	241	368	260	7.78	330	419
38FKT1200	25	724	236	9.93	254	394	366	15.49	432	470
42FKT1200	25	826	307	15.91	279	419	559	27.49	432	508
46FKT1200	32	927	369	24.29	279	432	597	36.03	432	508
52FKT1200	32	1067	510	42.10	318	470	818	63.73	432	584
51FKT1600	32	1067	669	48.41	381	508	1044	83.90	508	635
60FKT1600	44	1245	1145	127.7	406	660	1879	209.1	610	762
66FKT1600	51	1308	2241	284.5	508	864	2925	384.7	762	864
SI	Milímetros	Kg	Kg.m ²	Milímetros	Kg	Kg.m ²	Milímetros			



FKT - Componentes de Montaje

Datos Técnicos y Dimensionales

Cubo Adaptador - Serie Angosta

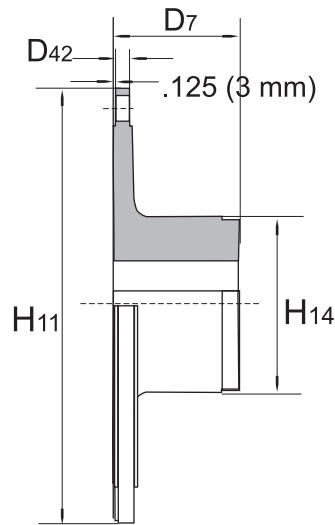

Agujero pasante o roscado

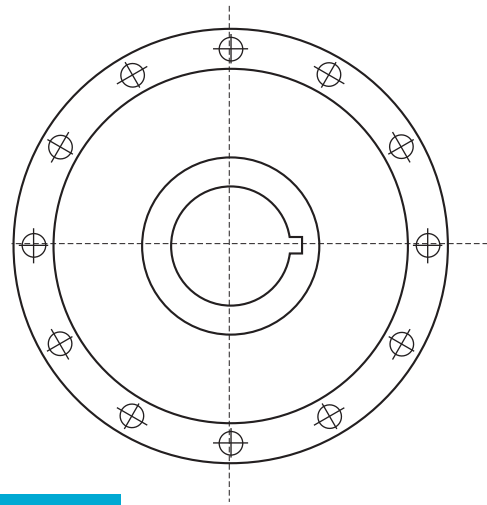

TAMAÑO	Cubo adaptador			
	Llanta Simple		Llanta Dual	
	Agujero Pasante	Agujero Roscado	Agujero Pasante	Agujero Roscado
11,5FKT500	226630	226632	226631	226633
14FKT500	226640	226642	226641	226643
16FKT600	226650	226652	226651	226653
20FKT600	226660	226662	226661	226663
24FKT650	226670	226672	226671	226673
28FKT650	226680	226682	226681	226683
33FKT650	226690	226692	226691	226693
37FKT650	226700	226702	226701	226703
42FKT650	226710	226712	226711	226713

NOTAS:

1- Peso referido a mínimo Ø de eje.

INGLES	Pulgadas	lb	lb-ft ²	Dimensiones en pulgadas			lb	lb-ft ²	Dimensiones en pulgadas			
11,5FKT500	10.25	54	4	5.00	0.63	7.00	64	4	5.75	0.75	7.50	
14FKT500	13.50	82	8	5.75	0.75	7.50	82	8	5.75	0.75	7.50	
16FKT600	15.00	99	14	5.75	0.75	8.00	108	15	6.50	0.75	8.00	
20FKT600	20.00	147	34	6.50	0.75	8.50	166	34	7.00	0.75	10.00	
24FKT650	23.00	192	56	6.50	0.75	9.50	250	68	7.50	0.75	12.00	
28FKT650	26.50	250	106	8.00	0.75	9.50	324	119	8.00	0.75	13.00	
32FKT650	33.50	374	214	9.00	0.75	11.00	532	342	9.50	1.00	14.50	
38FKT650	36.00	434	294	9.00	0.75	11.00	595	360	10.00	0.75	15.50	
42FKT650	41.50	663	536	10.00	0.75	13.50	769	608	11.00	0.75	16.50	
Tamaño	H ₁₁	Peso ϕ Wk ²		D ₇	D ₄₂	H ₁₄	Peso ϕ Wk ²		D ₇	D ₄₂	H ₁₄	
		Para Llanta Simple						Para Llanta Dual				
		Peso ϕ J	D ₇	D ₄₂	H ₁₄	Peso ϕ J	D ₇	D ₄₂	H ₁₄			
11,5FKT500	260	24	0.17	127	16	178	29	0.17	146	19	191	
14FKT500	343	37	0.34	146	19	191	37	0.34	146	19	191	
16FKT600	381	45	0.59	146	19	203	49	0.63	165	19	203	
20FKT600	508	67	1.43	165	19	216	75	1.43	178	19	254	
24FKT650	584	87	2.35	165	19	241	113	2.86	191	19	305	
28FKT650	673	113	4.46	203	19	241	147	5.01	203	19	330	
32FKT650	851	170	9.00	229	19	279	241	14.39	241	25	368	
38FKT650	914	197	12.37	229	19	279	270	15.15	254	19	394	
42FKT650	1054	287	22.56	254	19	343	349	25.59	279	19	419	
SI	mm	Kg	Kg.m ²	Dimensiones en milímetros			Kg	Kg.m ²	Dimensiones en milímetros			



ELEMENTOS INDUSTRIALES.

BV,27 de Febrero al 4000, Esq, Lavalle.
(2000) Rosario Santa Fe - Argentina

Departamento de Ventas Nacionales

Tel.: (0341) 487 2022

WhatsApp: (341) 356 2022

ventas@elementosindustriales.com.ar

Departamento de Ventas Internacionales

Tel. / Fax: (54-0341) 510 4421

info@elementosindustriales.com.ar

www.elementosindustriales.com.ar

